

# Schlüter®-BEKOTEC-THERM

Illustrated price list BT 19

Export · Effective 1 January 2019



2019



## Schlüter®-BEKOTEC-THERM

### The ceramic thermal comfort floor

#### Energy-efficient, comfortable, reliable.

Floor heating systems are the ideal medium for environmentally sound and economical heating due to their large-scale heat distribution across the entire space. In construction practice, it is difficult to balance the structural, physical and heating-technology requirements for a floor heating system. The specifications of the corresponding building codes, for example with regard to screed thickness, movement joints, reinforcement inserts, or residual moisture have frequently proven inadequate for practical applications in the past. Thus, conventional heated screeds with tile or stone coverings often buckle or form cracks. This is mainly attributable to the fact that screed and tile or stone expand and contract differently due to their divergent heat expansion coefficients during temperature changes.

From the perspective of heating technology, the relatively large screed volume of conventional assemblies has the disadvantage that a large amount of heating energy has to be supplied and stored. Accordingly, conventional floor heating systems are slow to respond to temperature changes. The complete system Schlüter®-BEKOTEC-THERM solves these problems comprehensively and is protected as an international process patent.

The “BEKOTEC” component in the name represents the covering assembly technology, while “THERM” stands for the heating components. The system is based on a thin screed, which is applied over the studded BEKOTEC panels and reduces shearing tensions in the studded pattern. If Schlüter®-DITRA 25, Schlüter®-DITRA-DRAIN 4 or Schlüter®-DITRA-HEAT are used, tiles or natural stone panels can be installed as soon as the screed is ready to bear weight.



Nachhaltiges Gebäude  
DGNB Zertifikat in Platin

*The German Sustainable Building Council (DGNB) has recognised Schlüter-WorkBox, the new training center in Iserlohn, with a platinum certificate for comprehensive sustainability.*



The small screed volume and the closeness of the heating pipes to the surface enable quick heating and cooling of the floor. The interconnected air channels of the uncoupling mat below the tiles result in even heat distribution. This makes Schlüter®-BEKOTEC-THERM a quick-reacting “ceramic thermal comfort floor” that can be operated with great energy efficiency at very low supply temperatures. Of course, other materials can be installed over the BEKOTEC screed as well. Schlüter®-BEKOTEC-THERM has been proven in domestic and international projects for years, whenever quick construction progress and ecologically sound heating are priorities. The LEED certification of our administrative building in Montreal and Reno plus the DGNB platinum certificate for sustainability awarded to the training center in Iserlohn are objective confirmations of the system’s sustainability.



*Certified with a gold medal of the LEED program (Leadership in Energy and Environmental Design): Administrative building in Montreal (shown on the left) and Reno equipped with the ceramic thermal comfort floor Schlüter®-BEKOTEC-THERM.*



# Schlüter®-BEKOTEC-THERM

## Our service

- **Technical consulting**
- **Determination of material requirements**
- **Calculation service**
- **Materials for tenders**

### **Technical consulting**

The experienced employees of our Technical Department will be pleased to assist you with any questions you may have concerning the construction assembly and the corresponding heating and control technology. The Department also develops individual construction designs and solutions for your building projects.

### **Heating load calculation**

Our software solution allows us to determine the heating load of buildings and individual rooms on the basis of the corresponding drawings and data in order to guarantee the most efficient heat distribution of the Schlüter®-BEKOTEC-THERM ceramic thermal comfort floor.

### **Heating system design**

We can use existing drawings, information about the number and size of rooms, as well as the corresponding heating load to design the heating system. This includes the determination of the required heating circuits and the optimal installation spacing. The system generates a material list that includes all necessary components. Such lists can be supplied as tables or as CAD drawings with heating circuits.



### **Materials for tenders**

We can develop customised materials for tender based on the technical design of Schlüter®-BEKOTEC-THERM as a radiant panel heating system.

### **Onsite consulting**

Please contact our offices if you need professional advice onsite. We will be pleased to arrange an appointment.



## Schlüter®-BEKOTEC-THERM – The Ceramic Thermal Comfort Floor System assembly

This picture shows the assembly structure of the **Schlüter®-BEKOTEC-THERM** ceramic thermal comfort floor with the associated system components. The numbers in the image represent the corresponding products of the system assembly. In addition, we can provide detailed technical data sheets for more comprehensive information.

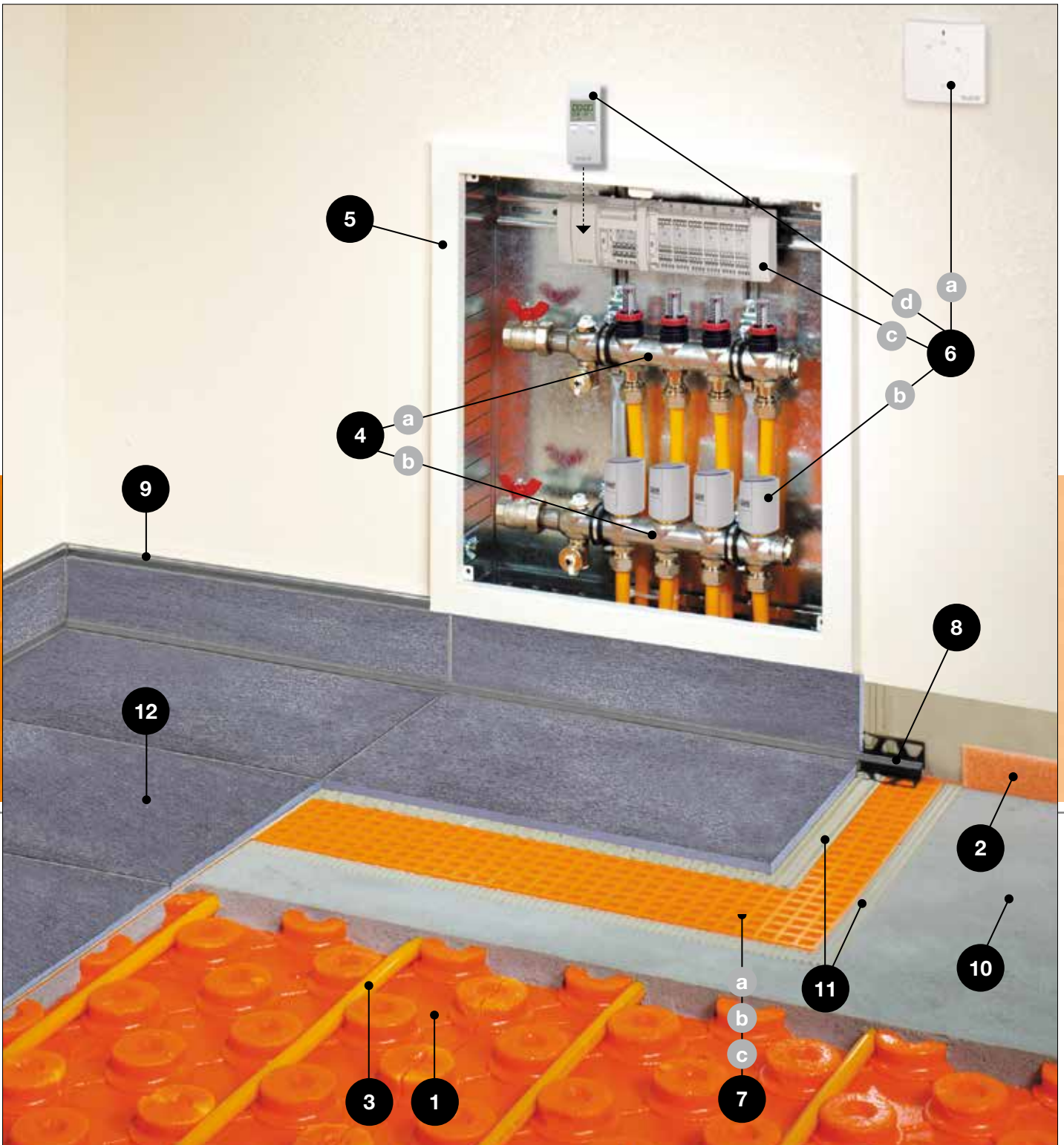



## Schlüter®-BEKOTEC-THERM

System components of the modular radiant heated floor assembly:

- 1 Schlüter®-BEKOTEC-EN**  
Studded screed panel for the attachment of Schlüter heating pipes. Additional insulation and construction standards must be observed in accordance with the applicable technical guidelines.
- 2 Schlüter®-BEKOTEC-BRS**  
Screed edge strip  
The edge strip BRS 808 KSF must be used with the studded panel EN 23 F and EN 18 FTS. The edge strip BRS 505 KSF is designed for use with EN 12 FK.
- 3 Schlüter®-BEKOTEC-THERM-HR**  
Heating pipe
- 4 Schlüter®-BEKOTEC-THERM-HV**  
Stainless steel heating circuit distributor manifolds with connection accessories
  - a hot flow leg
  - b cold return leg
- 5 Schlüter®-BEKOTEC-THERM-VS**  
Distributing cabinet
- 6 Schlüter®-BEKOTEC-THERM-E**  
Electronic room control
  - a room sensor
  - b actuator
  - c base module "Control" with connection module
  - d timer unit (optional)

### System components

for the installation of tile and natural stone (see separate price list)

- 7 a Schlüter®-DITRA 25**  
Uncoupling, heat distribution, bonded water proofing, vapour pressure equalisation or  
**b Schlüter®-DITRA-DRAIN 4**  
Bonded uncoupling, heat distribution, vapour pressure equalisation or  
**c Schlüter®-DITRA-HEAT-E**  
Bonded uncoupling, waterproofing with electrical floor heating
- 8 Schlüter®-DILEX-EK or -RF**  
Maintenance free edge and movement joint profiles
- 9 Schlüter®-RONDEC, Schlüter®-JOLLY or Schlüter®-QUADEC**  
Decorative finishing profiles for walls and skirting

### System components

not available from Schlüter-Systems

- 10 Screed**  
Cement or calcium sulfate screed
- 11 Thin-bed tile adhesive**
- 12 Ceramic tiles or natural stone**  
Other coverings such as carpet, laminates or parquet are also feasible in compliance with the applicable installation standards.

### Systems for renovation projects

#### Schlüter®-BEKOTEC-EN 18 FTS

with integrated sound insulation is installed as a floating system directly on weight-bearing substrates with load distribution.

#### Schlüter®-BEKOTEC-EN 12 FK

is directly adhered to weight-bearing substrates with load distribution.

Contents:	Page
Service .....	3
All-round systems .....	6
Renovation systems .....	8
Overview of control technology .....	10
<b>Schlüter®-BEKOTEC-EN</b> <b>1</b> .....	12
Studded screed panels .....	12
<b>Schlüter®-BEKOTEC-BRS</b> <b>2</b> .....	16
Screed edging strip .....	16
<b>Schlüter®-BEKOTEC-THERM-HR</b> <b>3</b> .....	19
Heating pipes .....	19
<b>Schlüter®-BEKOTEC-THERM-HV</b> <b>4</b> .....	20–21
Heating circuit distributor manifolds with accessories .....	20–21
<b>Schlüter®-BEKOTEC-THERM-RVT/BMS/RTB</b> .....	24–26
Fixed value control, return temperature limit valve, room temperature control valve .....	24–26
<b>Schlüter®-BEKOTEC-THERM-VS</b> <b>5</b> .....	27
Distribution cabinets .....	27
<b>Schlüter®-BEKOTEC-THERM-ER</b> <b>6a</b> .....	28
Room sensors .....	28
<b>Schlüter®-BEKOTEC-THERM-EBC/-EAR</b> <b>6c</b> .....	28–30
Control technology .....	28–30
<b>Schlüter®-BEKOTEC-THERM-EET</b> <b>6d</b> .....	29
Timer unit .....	29
<b>Schlüter®-BEKOTEC-THERM-ESA</b> <b>6b</b> .....	30
Actuators .....	30
Calculation help .....	32
Other system components .....	33

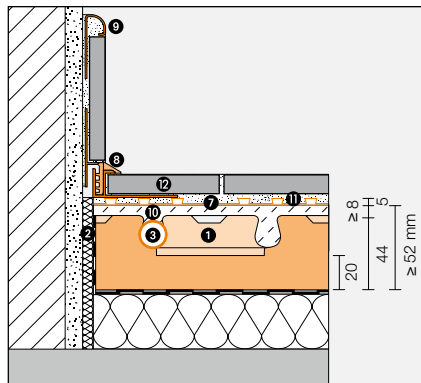

Assembly with Schlüter®-BEKOTEC-EN/P or Schlüter®-BEKOTEC-EN/PF with 16 x 2 mm heating pipe

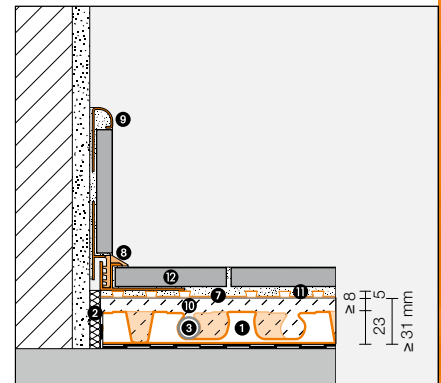

Assembly with Schlüter®-BEKOTEC-EN 23 F and 14 x 2 mm heating pipe

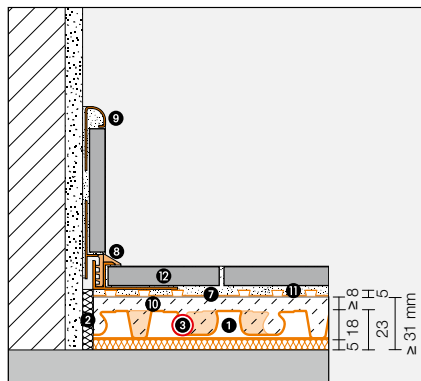

Assembly with Schlüter®-BEKOTEC-EN 18 FTS with heating pipe 12 x 1.5 mm

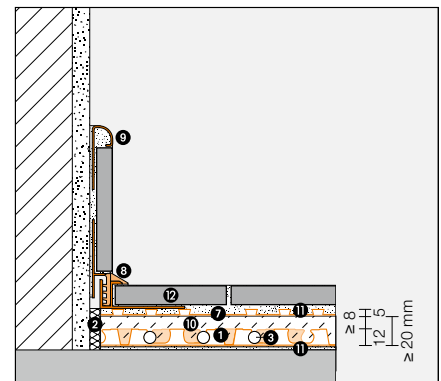

Assembly with Schlüter®-BEKOTEC-EN 12 FK with heating pipe 10 x 1.3 mm

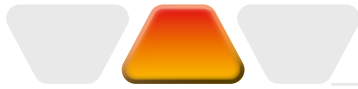

## Schlüter®-BEKOTEC-THERM

### All-round systems

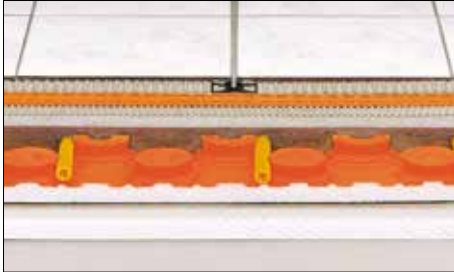

Schlüter®-BEKOTEC-EN

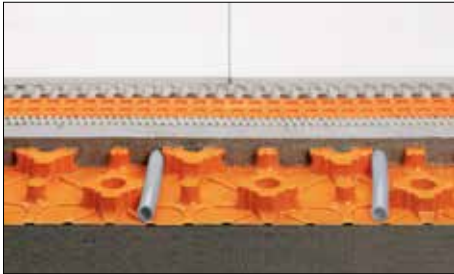

Schlüter®-BEKOTEC-EN F

**Schlüter®-BEKOTEC-THERM** is a safe floor assembly with low construction height. In conjunction with the matching heating and control technology, the modular system results in an energy efficient and quick reacting radiant heated floor system with low water supply temperatures. The system is based on the studded screed panel, **Schlüter®-BEKOTEC-EN**, which is directly installed on top of a load bearing substrate and/or conventional heat and sound insulation panels.

The studs are spaced in such a way that the Schlüter heating pipes can be installed at regular intervals to suit the room requirements; the studs are spaced at intervals of 75 mm. Screed mortar CT-C25-F4 (ZE 20) or CA-C25-F4 (AE 20) (maximum flexural strength F5) covers the studs and the heating pipes by a minimum of 8 mm and maximum of 25 mm. This results in a screed thickness of at least 32 mm between the studs.

The contraction that occurs when the screed cures is reduced within the pattern of the studs, so that no tension can build as a consequence of contraction buckling. It is therefore not necessary to divide the screed into separate fields with movement joints. Upright structural elements need to be secured with edging strips and construction joints will be carried over into the floor assembly. Once the screed is ready to support weight, the **Schlüter®-DITRA 25** or **Schlüter®-DITRA-DRAIN 4** uncoupling mat is installed. Ceramic tiles or natural stone can be installed directly on top of this layer in thin-bed tile adhesive. Movement joints in the cover layer above Schlüter®-DITRA should be established with **Schlüter®-DILEX** in the usual spacing.

Since the screed mass to be heated or cooled is comparatively small, the radiant heated floor is easily regulated and can be operated with low supply temperatures.

The electronic Schlüter control components, which are also available in wireless versions and are coordinated with the system, also allow for the quick and accurate control of the Schlüter®-BEKOTEC-THERM ceramic thermal comfort floor. The modular structure of the entire Schlüter control technology allows for simple installation and operation.

### A wide range of requirements is placed on heated floor constructions

- Heat and sound insulation
- Support and distribution of traffic loads
- Waterproofing in wet rooms
- Usable area and design element
- Function as “large area heating element”

In addition to ceramic tile and natural stone, other coverings such as parquet, laminates and carpet can also be used, following the applicable installation standards.

With **Schlüter®-BEKOTEC-THERM** we have achieved a balance of the varied requirements placed on heated floors. The modular system allows for simple, effective and building wide coordination and installation.

**Schlüter®-BEKOTEC-THERM** – The Ceramic Thermal Comfort Floor

**Simple. Safe. Fast.**



## Design benefits

- The **Schlüter®-BEKOTEC-THERM** ceramic thermal comfort floor is an easily coordinated modular system that is economical and effective, with low construction height and short installation time for new buildings and refurbishment. It is suitable for private homes as well as commercial areas such as office buildings, salesrooms and car dealerships.
- Once **Schlüter®-BEKOTEC-THERM** has been installed as the heating system, no other obstructive heating elements are required. This allows for maximum design freedom.
- In addition to ceramic tiles and natural stone coverings, other coverings such as parquet, laminates, or carpet can be installed, offering a great variety of design choices.

<b>Schlüter®-BEKOTEC-THERM: construction benefits</b>	
Advantage	Explanation
<b>Low construction height</b>	<ul style="list-style-type: none"> <li>• <b>Schlüter®-BEKOTEC-THERM</b> can be installed with construction heights starting at 31 mm plus covering.</li> <li>• This results in a wide range of application options for new construction and refurbishment.</li> </ul>
<b>Material and weight savings</b>	<ul style="list-style-type: none"> <li>• Due to the low screed mass, the weight of 1 m<sup>2</sup> of screed is only 57 kg.</li> <li>• Compared to conventional heated screeds, a reduction of 37 mm in screed thickness saves 3.7 m<sup>3</sup> of screed mortar with the weight of approximately 7.4 t over an area of 100 m<sup>2</sup>.</li> <li>• This has a positive impact on the static calculations of new construction or refurbishment projects.</li> <li>• The building is also spared the corresponding amount of moisture.</li> </ul>
<b>Screed construction with low tension</b>	<ul style="list-style-type: none"> <li>• Shrinkage stresses in the screed are evenly reduced in the studded pattern of the <b>Schlüter®-BEKOTEC</b> screed panel.</li> <li>• The screed does not buckle due to internal tensions.</li> <li>• No constructive reinforcement is necessary.</li> </ul>
<b>No screed joints</b>	<ul style="list-style-type: none"> <li>• The tensions in the screed are evenly reduced across the entire area. Therefore, it is not necessary to divide the screed into fields with movement joints.</li> </ul>
<b>More design options</b>	<ul style="list-style-type: none"> <li>• Free choice of movement joints in the joint pattern of the ceramic covering over <b>Schlüter®-DITRA 25</b> or <b>Schlüter®-DITRA-DRAIN 4</b>, since the joints from the screed do not have to be carried over.</li> </ul>
<b>Short construction time</b>	<ul style="list-style-type: none"> <li>• <b>Schlüter®-DITRA 25</b> or <b>Schlüter®-DITRA-DRAIN 4</b> can be installed as soon as the screed is ready to support weight, followed by the tile covering. For calcium sulfate screeds, the residual moisture should be approximately 2 %.</li> <li>• No warm up or cure heating is required.</li> <li>• No CM measurements to determine residual moisture.</li> <li>• Less material, therefore quicker installation.</li> </ul>
<b>Crack free ceramic or natural stone covering</b>	<ul style="list-style-type: none"> <li>• The low tension screed construction and uncoupling properties of <b>Schlüter®-DITRA 25</b> or <b>Schlüter®-DITRA-DRAIN 4</b> make sure stresses are not transferred to the covering.</li> </ul>
<b>Highly durable</b>	<ul style="list-style-type: none"> <li>• Loads in private and commercial buildings of up to 5 kN/m<sup>2</sup> are no problem (additional insulation must be able to sustain the corresponding pressure).</li> </ul>
<b>Proven suitability</b>	<ul style="list-style-type: none"> <li>• Damage free practical application.</li> <li>• Numerous reference projects.</li> <li>• Test certificates from independent institutes.</li> </ul>



### Note:

When installing coverings other than ceramic tile or natural stone, the applicable building standards for the covering must be followed, e.g. residual moisture at final curing.

<b>Schlüter®-BEKOTEC-THERM: heating benefits</b>	
Advantage	Explanation
<b>Quick reacting radiant heated floors</b>	<ul style="list-style-type: none"> <li>• The low screed mass allows for quick control response, e.g. when lowering the temperature at night.</li> </ul>
<b>Even distribution of heat</b>	<ul style="list-style-type: none"> <li>• The interconnected air channels of <b>Schlüter®-DITRA 25</b> or <b>Schlüter®-DITRA-DRAIN 4</b> below the ceramic covering allow for an even distribution of heat.</li> </ul>
<b>Low supply temperature, low heating cost</b>	<ul style="list-style-type: none"> <li>• The even, quick and large scale heat performance is highly efficient.</li> </ul>
<b>Effective for the utilisation of renewable energy sources</b>	<ul style="list-style-type: none"> <li>• The effective heating performance with low supply temperatures translates into a high degree of efficiency, e.g. for heating pumps or solar equipment.</li> </ul>
<b>Easy to control</b>	<ul style="list-style-type: none"> <li>• The optimised control technology allows for accurate temperature settings.</li> </ul>
<b>Comfort level</b>	<ul style="list-style-type: none"> <li>• The mild radiation heat of the floor as a "large scale heating element" makes for maximum comfort.</li> <li>• The option to combine wireless and wired individual room controls enables a particularly high degree of flexibility both in new buildings and in renovation projects.</li> </ul>
<b>Sanitary and healthy</b>	<ul style="list-style-type: none"> <li>• The heated, dry floor areas don't give insects such as mites and mould spores a chance.</li> <li>• The evenly radiated heat reduces the growth of mold and the germination of spores.</li> <li>• Ceramic tile and natural stone coverings are especially easy to care for and are hygienic.</li> </ul>
<b>Cooling</b>	<ul style="list-style-type: none"> <li>• With the corresponding application technology, rooms can be kept at a basic cool temperature.</li> </ul>

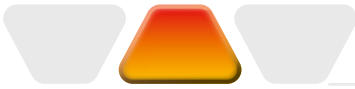

## Schlüter®-BEKOTEC-THERM

### Restoration systems

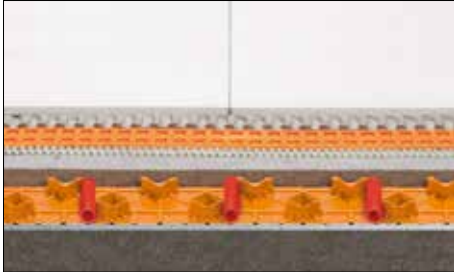

Schlüter®-BEKOTEC-EN FTS

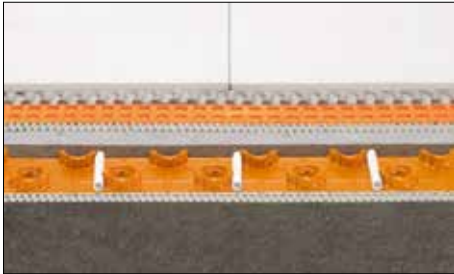

Schlüter®-BEKOTEC-EN FK

**Schlüter®-BEKOTEC-THERM** is ideally suited for creating heated and unheated screed in renovation projects because of its thin-layered structure. The variations **Schlüter®-BEKOTEC-EN 18 FTS** and **Schlüter®-BEKOTEC-EN 12 FK** were specifically developed for such applications. The low assembly height and small screed volume result in minimal static loads.

**Schlüter®-BEKOTEC-EN 18 FTS** is installed as a floating system on existing, weight-bearing substrates or old coverings if applicable. The sound insulation layer integrated below the studded screed panel can reach sound insulation values of up to 25 dB. With a coverage of min 8 mm / max. 20 mm over the studs, the assembly height is 31 to 43 mm.

**Schlüter®-BEKOTEC-EN 12 FK** is installed as a bonded assembly on existing, weight-bearing substrates or old coverings if applicable. The 12 mm studs are covered with min. 8 mm / max. 15 mm of screed allowing for assembly heights of 20 to 27 mm.

**Schlüter®-BEKOTEC-THERM** is ideally suited for the construction of energy-efficient ceramic thermal comfort floors in conjunction with ceramic tile and natural stone and the **Schlüter®-DITRA 25** membrane. However, all other floor coverings that are suitable for use with floor heating are equally feasible.



**Schlüter®-BEKOTEC-THERM** – The Ceramic Thermal Comfort Floor

**Simple. Safe. Fast.**





## Schlüter®-BEKOTEC-EN 18 FTS

### Advantage

- Easy floating installation
- Integrated 25 dB sound insulation
- Option to install over wooden floors
- Screed thicknesses from 26 mm (31 mm incl. 5 mm sound insulation)
- Heated or unheated
- Panels in convenient sizes
- Impact-resistant studded panel
- 50 mm installation grid for heating pipes
- Fully functional ceramic thermal comfort floor
- All benefits of the ceramic thermal comfort floor
- Installation with all floor coverings suitable for floor heating
- Low static load due to system weight from 52 kg/m<sup>2</sup> or 26 l/m<sup>2</sup>
- Suitable for cement-based and calcium sulfate screeds
- Complete accessory range

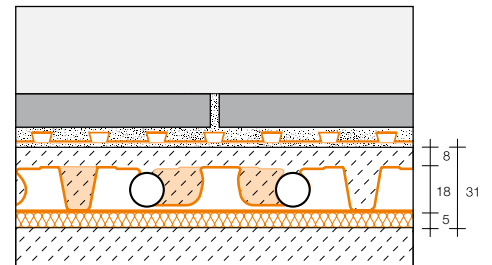

**Assembly with Schlüter®-BEKOTEC-EN 18 FTS with heating pipe 12 x 1.5 mm**  
Thin-layer ceramic thermal comfort floor with impact sound insulation on existing screed

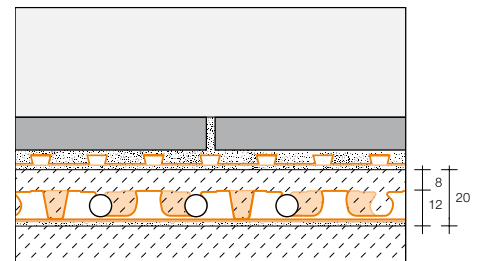

**Assembly with Schlüter®-BEKOTEC-EN 12 FK with heating pipe 10 x 1.3 mm**  
Thin-layer ceramic thermal comfort floor on existing screed

## Schlüter®-BEKOTEC-EN 12 FK

### Advantage

- Renovation over existing screed/covering as an option
- Can be adhered to wooden floor structures
- Bonded screed assembly
- Screed thicknesses from 20 mm
- Heated or unheated
- Panels in convenient sizes
- Impact-resistant studded panel
- 50 mm installation grid for heating pipes
- Fully functional ceramic thermal comfort floor
- All benefits of the ceramic thermal comfort floor
- Installation with all floor coverings suitable for floor heating
- Connection to existing heating systems as an option
- Low static load due to system weight from 40 kg/m<sup>2</sup> or 20 l/m<sup>2</sup>
- Suitable for cement-based and calcium sulfate screeds
- Complete accessory range





# Schlüter®-BEKOTEC-THERM

## Flexible control technology

### 1.1 ER/WL Room sensors, wireless version



Our new control technology makes the ceramic thermal comfort floor even more flexible. Both wireless and wired installations are feasible and can also be combined as a particular system benefit. The resulting technology system effectively leverages the ecological and economic benefits of BEKOTEC-THERM.

The renowned Dresden Institute for Building Systems Engineering Research has documented in a study that this allows for saving up to 9.5% of energy with the BEKOTEC-THERM system compared to conventional floor heating systems.

### 1.2 ER Room sensors, wired version

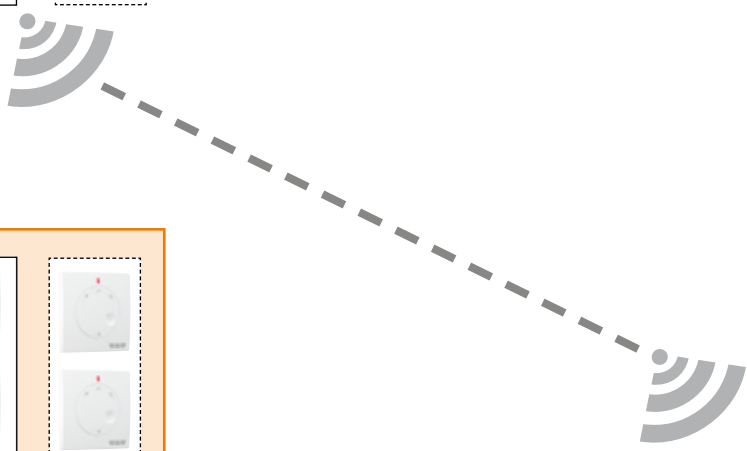

### 2.3 Connection module, wireless version for 6 ER/WL room sensors



### 2.4 Connection module, wired version for 6 ER room sensors



### 2.2 EET Timer unit (optional)



### 2.1 EBC "Control" base module



### 3 ESA Actuators



Expansion options:  
Up to 4 actuators can be directly allocated to each room sensor connection module. Schlüter-Systems offers additional practical control module extensions. The expansion options, which can also include mixed combinations with wireless control, can cover a maximum of 18 sensors and 72 actuators.



## Components of control technology:

### ER room sensors

Two different design variants are available. The following applies to both: The setpoint temperature is adjustable from 8° to 30°C and can be restricted by the setpoint limiter below the dial. The optional timer unit EET at the "Control" base module EBC can be used for a time-controlled temperature reduction of 4°C.

1.1

#### ER/WL – room sensor, wireless version

Flat, specially designed "Cooling/heating" room sensor for wireless temperature control. The device wirelessly transmits the current room temperature and the setpoint value to the EAR/WL connection module. The power is supplied by the built-in photovoltaic cell or battery.

1.2

#### ER room sensor, wired version

Flat, specially designed "Cooling/heating" room sensor for wired temperature control. The device transmits the current room temperature and the setpoint value to the EAR connection module. The power is supplied with safe 5 V ultra-low voltage via the "Control" base module in conjunction with the EAR connection module.

2.3

#### EAR/WL connection module, wireless version

Modules for connecting 2 or 6 ER/WL wireless room sensors. The connection modules can simply be plugged together to adjust and expand the number of rooms/heating circuits to be regulated and the matching actuators. Each channel of the connection module can be assigned to 4 actuators. Combination with wired EAR connection modules is possible.

2.4

#### EAR connection module, wired version

Modules for connecting 2 or 6 ER wired room sensors. The connection modules can simply be plugged together to adjust and expand the number of rooms/heating circuits to be regulated and the matching actuators. Each channel of the connection module can be assigned to 4 actuators. Combination with wireless EAR/WL connection modules is possible.

3

#### ESA – actuators

The Schlüter actuators regulate the flow at the individual cold leg valves of the heating circuit distributor (each actuator controls one heating circuit). They are equipped with an optical function display and a valve adaptation control. They are easy to install by plugging in.

2.1

#### EBC "Control" base module

Base unit for operating the room temperature control. The wireless and wired connection modules for the room sensors are connected to the "Control" base module, making it easy to realise mixed installations and upgrades. The base module supplies the wired room sensors with 5 V ultra-low voltage via the respective connection modules and controls the connected actuators with 230 V AC.

2.2

#### EET timer unit

The optional EET timer unit is used for time control of the temperature reduction. It can be removed from the "Control" base module for programming the temperature reduction and plugged back in. In the cooler phase, the temperature is then reduced by 4°C.

Because it ensures the quick responsiveness of the BEKOTEC-THERM ceramic thermal comfort floor, the timer unit meets the requirements for highly adjustable systems.

2.3

EAR/WL  
Connection module,  
wireless version  
for 2 ER/WL room sensors



2.4

EAR  
Connection module, wired version  
for 2 ER room sensors

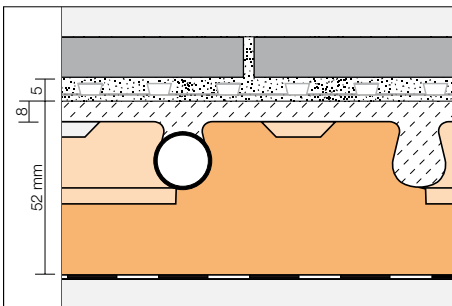
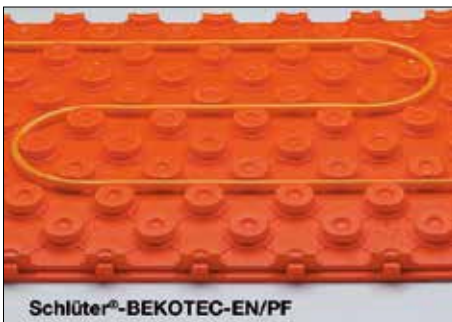
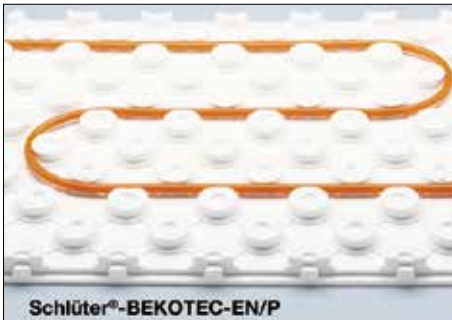

## Schlüter®-BEKOTEC-EN

**Schlüter®-BEKOTEC-EN** is a studded screed panel made of polystyrene, which is designed for the attachment of the **Schlüter®-BEKOTEC-THERM-HR** heating pipes, with a diameter of 16 mm. The panels are grooved for optimal joining. The heating pipes are attached in the desired spacing between the cutback studs, which are arranged in a regular spacing pattern of 75 mm. Conventional screed – CT-C25-F4 (ZE 20) or CA-C25-F4 (AE 20) (maximum flexural strength F5) – is installed above the studs with a thickness of at least 8 mm and at most 25 mm.

**Schlüter®-BEKOTEC-EN/P** consists of polystyrene (EPS 033 DEO), white, without foil coating and is most suited for conventional cement screeds.

**Schlüter®-BEKOTEC-EN/PF** is made of polystyrene (EPS 033 DEO) with an orange sheet coating and is therefore especially suited for flowing screeds (e.g. gypsum screeds).

### Technical data:

Installation spacing	75 - 150 - 225 - 300 mm
Approved heating pipe	BT HR 16 RT
Building material class	B2 acc. to DIN 4102
Heat conductor group	033 (0.033 W/mK)
U value	1.650 W/m <sup>2</sup> K
Thermal resistivity	0.606 m <sup>2</sup> K/W
Useable area	75.5 x 106 cm = 0.8 m <sup>2</sup>

### Note:

The uncoupling mat Schlüter®-DITRA must be adhered to the screed prior to the installation of ceramic tiles or natural stone on the screed. The mat can be installed as soon as the screed is ready to bear weight (gypsum screeds: < 2 % residual moisture).

Please observe the instructions of our product data sheets 6.1 and 9.1.

## Schlüter®-BEKOTEC-EN/P

studded screed panel without foil coating

Art.-No.	€/ m <sup>2</sup>	P (Unit)
EN 2520 P	14.94	20

### Note:

EN/P = screed panel without foil, e.g. conventional cementitious screeds

1 panel (0.8 m<sup>2</sup>) = smallest delivery unit

## Schlüter®-BEKOTEC-EN/PF

studded screed panel with foil coating

Art.-No.	€/ m <sup>2</sup>	P (Unit)
EN 1520 PF	17.94	20

### Note:

EN/PF = screed panel with sheet coating, suitable for flowing screeds, e.g. gypsum screeds

1 panel (0.8 m<sup>2</sup>) = smallest delivery unit



## Schlüter®-BEKOTEC-ENR

**Schlüter®-BEKOTEC-ENR** is an edge panel made of polystyrene (EPS 040 DEO) for optimising cuts of **Schlüter®-BEKOTEC** studded panels EN/P and EN/PF, adding small areas or filling small spaces between walls and upright structural elements.

### Technical data:

Useable area	30.5 x 45.5 cm = 0.14 m <sup>2</sup>
--------------	--------------------------------------

## Schlüter®-BEKOTEC-ENR

edge panel

Art.-No.	€/ U.	P (Unit)
ENR 1520 P	1.78	20

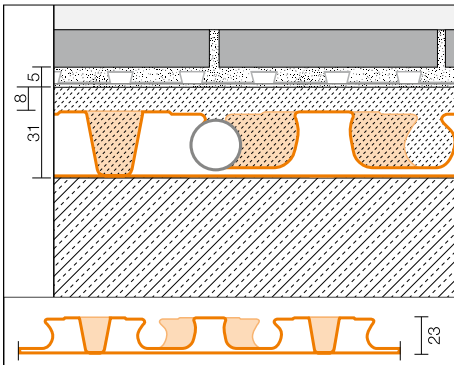
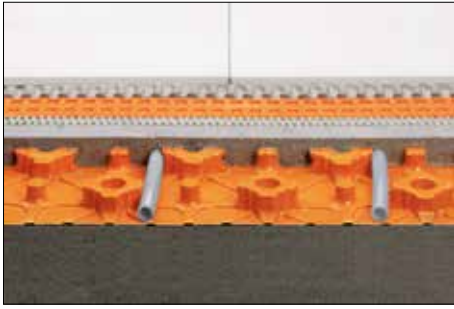

### Schlüter®-BEKOTEC-EN F

**Schlüter®-BEKOTEC-EN F** is a studded screed panel made of high impact polystyrene, designed for the attachment of the 14 mm heating pipes **Schlüter®-BEKOTEC-THERM-HR**. The **Schlüter®-BEKOTEC** panels are connected by overlapping a row of studs and clicking the panels together. The cutback studs hold the heating pipes in a precise 75 mm pattern, depending on the required pipe spacing. The screed is professionally installed as conventional screed of quality CT-C25-F4 (ZE20) or CA-C25-F4 (AE 20) (maximum flexural strength F5), with a coverage of at least 8 mm and no more than 25 mm above the studs.

Schlüter®-BEKOTEC-EN 23 F		
studded screed panel		
Art.-No.	€ / m <sup>2</sup>	P (Unit)
EN 23 F	14.07	20

**Note:**

The uncoupling mat Schlüter®-DITRA must be adhered to the screed prior to the installation of ceramic tiles or natural stone on the screed. The mat can be installed as soon as the screed is ready to bear weight (gypsum screeds: < 2 % residual moisture).

The edge strip BRS 808 KSF must be used with the studded screed panel EN 23 F and EN 18 FTS.

Please observe the instructions of our product data sheets 6.1 and 9.2.

**Technical data:**

Installation spacing	75 - 150 - 225 - 300 mm
Approved heating pipe	BT HR 14 RT
Building material class	B2 acc. to DIN 4102
Useable area	120 x 90 cm = 1.08 m <sup>2</sup>



### Schlüter®-BEKOTEC-ENFG

The levelling panel **Schlüter®-BEKOTEC-ENFG** is installed in the area of door openings and heating circuit distributors to simplify connections and to minimise cutting waste. It consists of polystyrene foil material and is adhered below the studded panels **Schlüter®-BEKOTEC-EN 23 F**, using the double sided adhesive tape.

Schlüter®-BEKOTEC-ENFG		
levelling panel with double sided adhesive tape (6 m)		
Art.-No.	€ / Set	P (Set)
ENFG	21.93	10

**Technical data:**

Useable area	127.5 x 97.5 cm = 1.24 m <sup>2</sup>
--------------	---------------------------------------

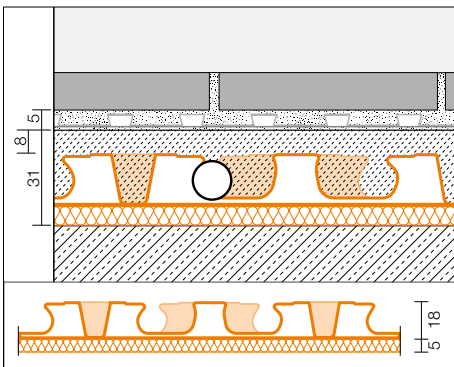
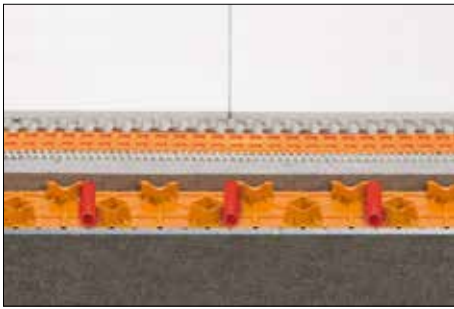

## Schlüter®-BEKOTEC-EN FTS

**Schlüter®-BEKOTEC-EN FTS** is a studded screed panel made of impact resistant polystyrene foil with additional 5 mm impact sound insulation on the underside. It is directly adhered on suitable, load bearing substrates.

The cutback studs hold the heating pipes Schlüter®-BEKOTEC-THERM-HR Ø 12 mm in a precise 50 mm pattern, depending on the required pipe spacing. The Schlüter®-BEKOTEC panels are connected by overlapping a row of studs and clicking the panels together. The screed is professionally installed as conventional screed of quality CT-C25-F4 (ZE 20) or CA-C25-F4 (AE 20) (flexural strength max. F5) with a coverage of at least 8 mm and no more than 20 mm above the studs.

### Technical data:

Installation spacing	50 - 100 - 150 - 200 - 250 - 300 mm
Approved heating pipe	BT HR 12 RT
Building material class	B2 acc. to DIN 4102
Useable area	140 x 80 cm = 1.12 m <sup>2</sup>

## Schlüter®-BEKOTEC-EN 18 FTS

**studded screed panel with impact sound insulation**

Art.-No.	€/ m <sup>2</sup>	P (Unit)
EN 18 FTS 5	<b>22.75</b>	20

### Note:

The uncoupling mat Schlüter®-DITRA must be adhered over the screed prior to the installation of ceramic tiles or natural stone. The mat can be installed as soon as the screed is sufficiently ready to bear weight (calcium sulfate screeds ≤ 2% residual moisture).

The edge strip BRS 808 KSF must be used with studded screed panels EN 18 FTS.

Please observe the instructions of our product data sheets 6.1 and 9.4.

Improvement in sound insulation:

An evaluation in accordance with DIN EN 717-2 determined an impact sound insulation improvement of up to 25 dB for the studded panel EN 18 FTS.



## Schlüter®-BEKOTEC-ENFGTS

The levelling panel **Schlüter®-BEKOTEC-ENFGTS** is used in door transitions and in front of heating circuit distributors to simplify the connection and reduce cutting waste. It consists of polystyrene foil material with additional 5 mm impact sound insulation on the underside and is adhered below the studded panel EN 18 FTS, using the supplied double sided adhesive tape.

### Technical data:

Useable area	140 x 80 cm = 1.12 m <sup>2</sup>
--------------	-----------------------------------

## Schlüter®-BEKOTEC-ENFGTS

**levelling panel for EN 18 FTS**

Art.-No.	€/ Set	P (Set)
EN 18 FGTS 5	<b>31.48</b>	10

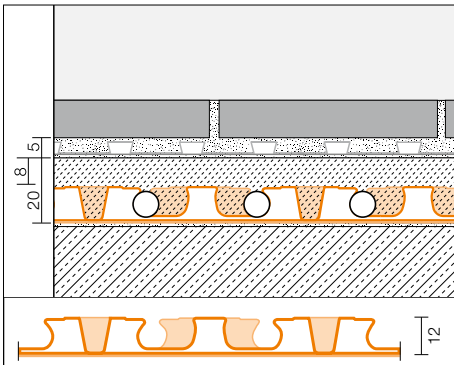
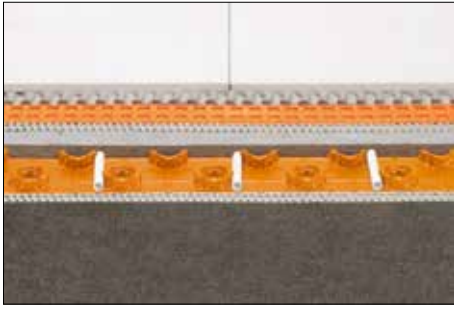

### Schlüter®-BEKOTEC-EN FK

**Schlüter®-BEKOTEC-EN FK** is a studded screed panel made of impact resistant polystyrene foil with an anchoring fleece laminated on the underside. It is adhered as a bonded assembly on suitable weight-bearing substrates. The cutback studs hold the heating pipes Schlüter®-BEKOTEC-THERM-HR Ø 10 mm in a precise 50 mm pattern, depending on the required pipe spacing. The Schlüter®-BEKOTEC panels are connected by overlapping a row of studs and clicking the panels together. The screed is professionally installed as conventional screed of quality CT-C25-F4 (ZE 20) or CA-C25-F4 (AE 20) (flexural strength max. F5) with a coverage of at least 8 mm and no more than 15 mm above the studs.

### Schlüter®-BEKOTEC-EN 12 FK

**studded screed panel with anchoring fleece on the underside**

Art.-No.	€/ m <sup>2</sup>	P (Unit)
EN 12 FK	15.11	20

**Note:**

The uncoupling mat Schlüter®-DITRA must be adhered over the screed prior to the installation of ceramic tiles or natural stone. The mat can be installed as soon as the screed is sufficiently ready to bear weight (calcium sulfate screeds ≤ 2% residual moisture).

The edge strip BRS 505 KSF must be used with studded screed panels EN 12 FK.

Please observe the instructions of our product data sheets 6.1 and 9.5.

**Technical data:**

Installation spacing	50 - 100 - 150 - 200 - 250 - 300 mm
Approved heating pipe	BT HR 10 RT
Building material class	B2 acc. to DIN 4102
Useable area	110 x 70 cm = 0.77 m <sup>2</sup>



### Schlüter®-BEKOTEC-ENFGK

The levelling panel **Schlüter®-BEKOTEC-ENFGK** is used in door transitions and in front of heating circuit distributors to simplify the connection and reduce cutting waste. It consists of polystyrene foil material and is adhered below the studded panel EN 12 FK, using the supplied double sided adhesive tape.

### Schlüter®-BEKOTEC-ENFGK

**levelling panel for EN 12 FK**

Art.-No.	€/ Set	P (Set)
EN 12 FGK	21.36	10

**Technical data:**

Useable area	110 x 70 cm = 0.77 m <sup>2</sup>
--------------	-----------------------------------



### Schlüter®-BEKOTEC-ZDK

**Schlüter®-BEKOTEC-ZDK66** is a double sided adhesive tape for adhering the studded panel to the substrate or the levelling panels.

### Schlüter®-BEKOTEC-ZDK

**double sided adhesive tape**

Art.-No.	€/ U.	P (Unit)
BTZDK66	63.04	10

**Technical data:**

Dimensions (T x W x L)	1 mm x 30 mm x 66 m
------------------------	---------------------

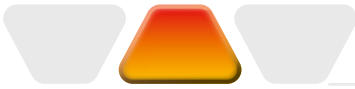

### Schlüter®-BEKOTEC-BTS

**Schlüter®-BEKOTEC-BTS** is a 5 mm thick insulation layer of closed cell polyethylene foam for installation below the studded screed panels Schlüter®-BEKOTEC-EN/P and -EN/PF. The use of Schlüter®-BEKOTEC-BTS results in a significant improvement of sound insulation. The material can be used if the required construction height is not sufficient for a thick insulation layer of polystyrene or mineral fibre. The maximum floor load must be limited to 2 kN/m<sup>2</sup>.

#### Technical data:

Dimensions (T x W x L) 5 mm x 1 m x 50 m

### Schlüter®-BEKOTEC-BTS

#### PE impact sound insulation

Art.-No.	€/ m <sup>2</sup>	P (Roll)
BTS 510	4.33	5

1 roll (50 m<sup>2</sup>) = delivery unit



### Schlüter®-BEKOTEC-BRS

**Schlüter®-BEKOTEC-BRS** is an edging strip of closed cell polyethylene foam with an integrated foil leg. The edging strip is installed along walls or fixed room components. The foil leg is installed beneath the **Schlüter®-BEKOTEC** panels or the PE foil cover and is suitable for conventional cement screeds.

The finishing strip **Schlüter®-BEKOTEC-BRSK** is equipped with an additional adhesive strip for attachment to the wall.

#### Technical data:

Dimensions (T x W x L) 8 mm x 100 mm x 50 m

### Schlüter®-BEKOTEC-BRS

#### edging strip (BRS 810) edging strip self adhesive (BRSK 810)

Art.-No.	€/ m	P (Roll)
BRSK 810	1.15	10
BRS 810	0.87	10

1 roll (50 m) = delivery unit



### Schlüter®-BEKOTEC-BRS/KF

**Schlüter®-BEKOTEC-BRS/KF** is an edge strip of closed cell polyethylene foam with an adhesive leg and an adhesive backing for wall attachment. When the Schlüter®-BEKOTEC studded panel is laid on the PE adhesive, the resulting connection prevents flowing screeds from running underneath the assembly during installation.

#### Technical data:

Dimensions (T x W x L) 8 mm x 80 mm x 25 m

### Schlüter®-BEKOTEC-BRS/KF

#### edging strip with adhesive leg

Art.-No.	€/ m	P (Roll)
BRS 808 KF	1.85	10

1 roll (25 m) = delivery unit





### Schlüter®-BEKOTEC-BRS/KSF

**Schlüter®-BEKOTEC-BRS/KSF** is an edging strip of closed cell polyethylene foam with an integrated foil leg that features an adhesive strip on both sides for attachment. The edging strip is pressed toward the wall by the adhesion on the substrate and the pre tensioning of the integrated foil leg. When the studded panel Schlüter®-BEKOTEC is laid on top of the adhesive strip, flowing screed can no longer flow underneath the panel.

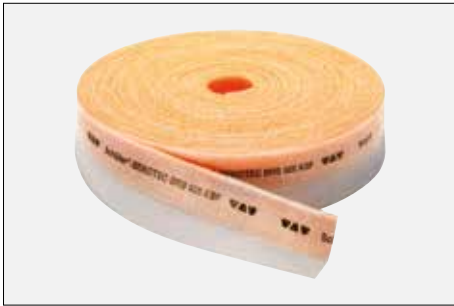

#### Technical data:

Dimensions	8 mm x 80 mm x 25 m (T x W x L)	(BRS 808 KSF)
	5 mm x 50 mm x 25 m	(BRS 505 KSF)

### Schlüter®-BEKOTEC-BRS/KSF

edging strip for flowing screeds  
with integrated foil leg

Art.-No.	€/m	P (Roll)
BRS 808 KSF	2.51	5

1 roll (25 m) = delivery unit

The edge strip BRS 808 KSF must be used with the studded screed panel EN 23 F and EN 18 FTS.

### Schlüter®-BEKOTEC-BRS/KSF

edging strip for flowing screeds  
with integrated foil leg

Art.-No.	€/m	P (Roll)
BRS 505 KSF	2.27	5

1 roll (25 m) = delivery unit

The edge strip BRS 505 KSF must be used with studded screed panels EN 12 FK.

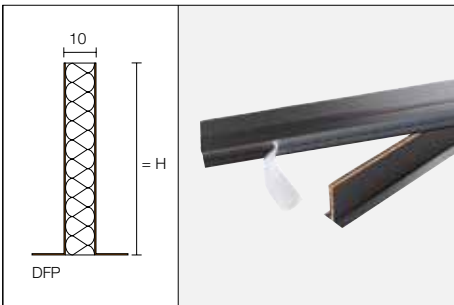

### Schlüter®-DILEX-DFP

**Schlüter®-DILEX-DFP** is a movement joint profile to be installed at door areas or used to divide screed areas.

### Schlüter®-DILEX-DFP

flexible movement joint

H (mm)	L = 1.00 m Art.-No.	€/m	P (Unit)
60	DFP 6/100	10.50	20
80	DFP 8/100	12.34	20
100	DFP 10/100	14.37	20

### Schlüter®-DILEX-DFP

flexible movement joint

H (mm)	L = 2.50 m Art.-No.	€/m	KV (Unit)
100	DFP 10/250	13.88	40

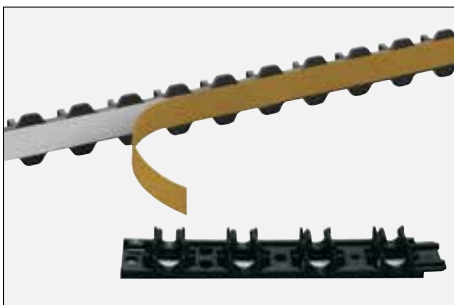

### Schlüter®-BEKOTEC-ZRKL

**Schlüter®-BEKOTEC-ZRKL** is a pipe clamping strip for securing the pipes on the levelling panel. The clamping strips are self-adhesive to allow for permanent attachment.

### Schlüter®-BEKOTEC-ZRKL

pipe clamping strip  
for heating pipes Ø 14-16 mm

L (cm)	Art.-No.	€/U.	P (Unit)
20	BTZRKL	4.76	10

Number of pipe spaces: 4

### Schlüter®-BEKOTEC-ZRKL

pipe clamping strip  
for heating pipes Ø 10-12 mm

L (cm)	Art.-No.	€/U.	P (Unit)
80	BTZRKL 1012	4.64	10

Number of pipe spaces: 32

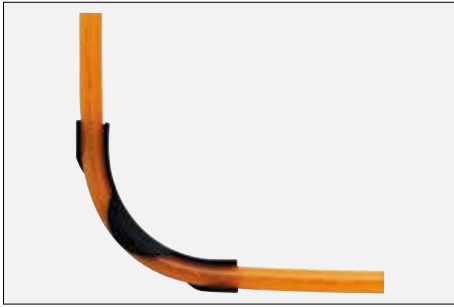

### Schlüter®-BEKOTEC-THERM-ZW

**Schlüter®-BEKOTEC-THERM-ZW** is an angle clip of synthetic material for defined 90° bends of the heating pipes Ø 10, 12, 14 or 16 mm in the distributor cabinet. The angle clip is easy to attach to the heating pipes from the side. Due to the relatively low thickness of the screed layer, the use of the clips is recommended.

Schlüter®-BEKOTEC-THERM-ZW			
angle clip			
Ø mm	Art.-No.	€ / U.	P (Unit)
10-12	BTZW 1014	2.21	50
14-16	BTZW 1418	2.27	50

**Note:**

2 units required per heating circuit (hot and cold leg).

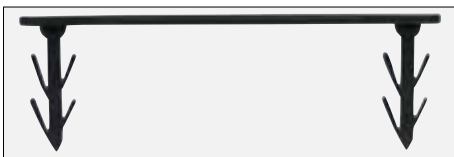

### Schlüter®-BEKOTEC-THERM-RH

**Schlüter®-BEKOTEC-THERM-RH 75** is an attachment clamp for the heating pipes, which can be anchored into the **Schlüter®-BEKOTEC** studded panels across the studs. It is especially useful for forming 45° angles with 16 mm heating pipes in the studded panel.

**Schlüter®-BEKOTEC-THERM-RH 17** is a plastic clip with barbs for anchoring 16 mm heating pipes into the Schlüter®-BEKOTEC studded panels.



Schlüter®-BEKOTEC-THERM-RH		
pipe clamps for 16 mm heating pipes		
Art.-No.	€ / Package	P (Package)
BTZRH 75/100	27.05	10
BTZRH 17/100	14.18	10

package = 100 units

**Note:**

Heating pipe clips are suitable for use with the studded panels EN/P and EN/PF only.



### Schlüter®-BEKOTEC-THERM-HRA

**Schlüter®-BEKOTEC-THERM-HRA** is a dispensing unit that accommodates disposable drums with Schlüter heating pipe. It can be assembled without tools and is easily disassembled for transport. Made of a coated steel frame construction.

**The unit consists of**

- One 25 mm spindle
- Two triangular frames
- Two connecting brackets

Schlüter®-BEKOTEC-THERM-HRA	
heating pipe dispenser	
Art.-No.	€ / U.
BTZHRA 750	283.56



## Schlüter®-BEKOTEC-THERM-HR

Schlüter®-BEKOTEC-THERM-HR is a heating pipe of high-quality PE-RT plastic. It is very flexible and allows for optimal installation in the Schlüter®-BEKOTEC studded screed panel. Diameters 10, 12, 14 or 16 mm, manufactured according to DIN 16833, oxygen-impermeable according to DIN 4721/26, SKZ quality-control A220.

### Shipping unit:

- 70 m in carton
- 120 m in carton
- 200 m in carton
- 750 m on disposable drum (Ø 14 + 16 mm)
- 1000 m on disposable drum (Ø 12 mm)
- 1500 m on disposable drum (Ø 10 mm)

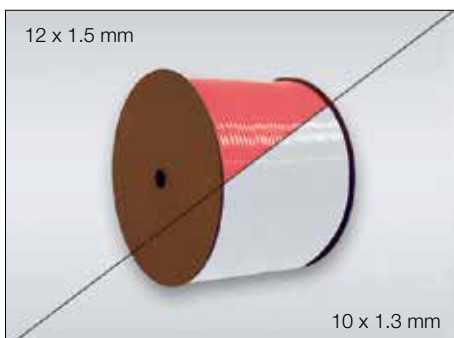

### Calculation of heating pipe requirements:

system	installation spacing (IS) in mm	heating pipe requirements in m/m <sup>2</sup>
EN/P, EN/PF, EN 23 F	75	13.33
	150	6.66
	225	4.44
	300	3.33
EN 18 FTS, EN 12 FK	50	20.00
	100	10.00
	150	6.66
	200	5.00
	250	4.00
	300	3.33

Our systems have been tested according to DIN EN 1264.

Schlüter®-BEKOTEC-THERM-HR			
heating pipe 16 mm for EN/P and EN/PF			
L (m)	Art.-No.	€/m	P (Roll)
70	BTHR 16 RT 70	1.66	15
120	BTHR 16 RT 120	1.66	15
200	BTHR 16 RT 200	1.66	15
750	BTHR 16 RT 750	1.66	4

Schlüter®-BEKOTEC-THERM-HR			
heating pipe 14 mm for EN 23 F			
L (m)	Art.-No.	€/m	P (Roll)
70	BTHR 14 RT 70	1.62	15
120	BTHR 14 RT 120	1.62	15
200	BTHR 14 RT 200	1.62	15
750	BTHR 14 RT 750	1.62	4

Schlüter®-BEKOTEC-THERM-HR			
heating pipe 12 mm for EN 18 FTS			
L (m)	Art.-No.	€/m	P (Roll)
70	BTHR 12 RT 70	1.55	15
120	BTHR 12 RT 120	1.55	15
200	BTHR 12 RT 200	1.55	15
1000	BTHR 12 RT 1000	1.55	4

Schlüter®-BEKOTEC-THERM-HR			
heating pipe 10 mm for EN 12 FK			
L (m)	Art.-No.	€/m	P (Roll)
70	BTHR 10 RT 70	1.47	15
120	BTHR 10 RT 120	1.47	15
200	BTHR 10 RT 200	1.47	15
1500	BTHR 10 RT 1500	1.47	4

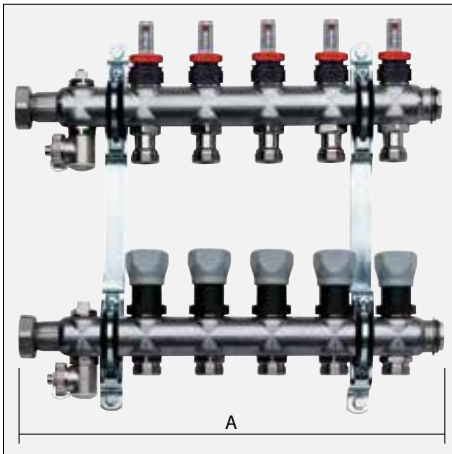

## Schlüter®-BEKOTEC-THERM-HV/DE Schlüter®-BEKOTEC-THERM-HV/A

**Schlüter®-BEKOTEC-THERM-HV/DE** is a heating circuit distributor manifold DN 25 of stainless steel with hot leg and cold leg bars, outside diameter 35 mm.

Two distributor manifold brackets with sound insulation inserts, matching the Schlüter distributor manifold cabinet, as well as a wall mounting set are included loosely in the package for installation.

### The integrated and pre assembled set includes:

- Hot leg flow meter with transparent scale, adjustable 0.5 to 5.0 l / minute for regulating flow quantities
- Thermostat valves, adjustable manually for every heating circuit, matching the electronically controlled Schlüter actuators
- Manual ventilation valve, nickel plated brass for hot and cold legs
- Filling and evacuation valve, 1/2" (DN 15), turning, nickel plated brass
- End plug 3/4" (DN 20), nickel plated brass
- Distributor connection, with 1" flat gasket male fitting (DN 25)
- Heating circuit terminals, spaced 55 mm apart, consisting of connector nozzle 3/4" (DN 20) AG with cone, matching the Schlüter clamp connections.

## Schlüter®-BEKOTEC-THERM-HV/DE Schlüter®-BEKOTEC-THERM-HV/A

		HV/DE = heating circuit distributor		HV/A = distributor connection set Ø 16 mm		HV/A = distributor connection set Ø 14 mm		
Number of heating circuits	Length A [mm]	Art.-No.	€/ Set	Art.-No.	€/ Set	Art.-No.	€/ Set	P (Set)
2	200	BTHV 2 DE	168.01	BTHV 2 A	53.36	BTHV 2 A 14	51.80	5
3	255	BTHV 3 DE	216.80	BTHV 3 A	66.79	BTHV 3 A 14	64.39	5
4	310	BTHV 4 DE	265.68	BTHV 4 A	80.20	BTHV 4 A 14	77.00	5
5	365	BTHV 5 DE	314.48	BTHV 5 A	93.61	BTHV 5 A 14	89.59	5
6	420	BTHV 6 DE	363.32	BTHV 6 A	107.05	BTHV 6 A 14	102.20	5
7	475	BTHV 7 DE	412.13	BTHV 7 A	120.45	BTHV 7 A 14	114.80	5
8	530	BTHV 8 DE	460.95	BTHV 8 A	133.87	BTHV 8 A 14	127.39	5
9	585	BTHV 9 DE	509.79	BTHV 9 A	147.26	BTHV 9 A 14	140.02	5
10	640	BTHV 10 DE	558.62	BTHV 10 A	160.66	BTHV 10 A 14	152.63	5
11	695	BTHV 11 DE	607.46	BTHV 11 A	174.09	BTHV 11 A 14	165.22	5
12	750	BTHV 12 DE	656.26	BTHV 12 A	187.48	BTHV 12 A 14	177.83	5

Connection set components	Ø 16 x 2 mm	Example: BTHV 5 A for 5 component heating circuit distributor	Ø 14 x 2 mm	Example: BTHV 7 A 14 for 7 component heating circuit distributor
Ball valves R 3/4"	2 units per distributor	2 units	2 units per distributor	2 units
Clamp connections	2 units per heating circuit	10 units	2 units per heating circuit	14 units
Angle clips	2 units per heating circuit	10 units	2 units per heating circuit	14 units
Heating pipe clamp RH 17	2 units per heating circuit	10 units	-	-
Heating pipe clamp RH 75	2 units per heating circuit	10 units	-	-

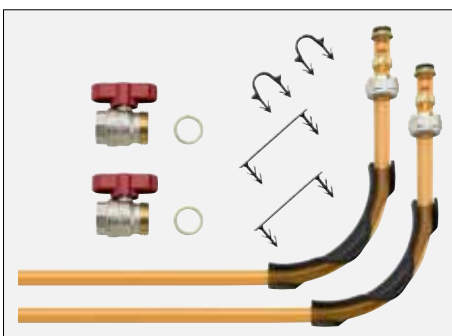

Example: Connection set of components for heating pipes with a diameter of 16 mm



## Schlüter®-BEKOTEC-THERM-HV/DE Schlüter®-BEKOTEC-THERM-HV/A

Accessory sets for connecting the heating circuits to the heating circuit distributor, for heating pipes with Ø 10, 12, 14 or 16 mm, including two ball valves for the main connection.

Example: Connection set of components for heating pipes with a diameter of 12 mm

		HV/DE = heating circuit distributor		HV/A = distributor connection set Ø 12 mm		HV/A = distributor connection set Ø 10 mm		
Number of heating circuits	Length A [mm]	Art.-No.	€/ Set	Art.-No.	€/ Set	Art.-No.	€/ Set	P (Set)
2	200	BTHV 2 DE	168.01	BTHV 2 A 12	52.74	BTHV 2 A 10	52.74	5
3	255	BTHV 3 DE	216.80	BTHV 3 A 12	64.70	BTHV 3 A 10	64.70	5
4	310	BTHV 4 DE	265.68	BTHV 4 A 12	77.74	BTHV 4 A 10	77.74	5
5	365	BTHV 5 DE	314.48	BTHV 5 A 12	90.18	BTHV 5 A 10	90.18	5
6	420	BTHV 6 DE	363.32	BTHV 6 A 12	103.57	BTHV 6 A 10	103.57	5
7	475	BTHV 7 DE	412.13	BTHV 7 A 12	116.40	BTHV 7 A 10	116.40	5
8	530	BTHV 8 DE	460.95	BTHV 8 A 12	129.41	BTHV 8 A 10	129.41	5
9	585	BTHV 9 DE	509.79	BTHV 9 A 12	141.85	BTHV 9 A 10	141.85	5
10	640	BTHV 10 DE	558.62	BTHV 10 A 12	155.22	BTHV 10 A 10	155.22	5
11	695	BTHV 11 DE	607.46	BTHV 11 A 12	168.01	BTHV 11 A 10	168.01	5
12	750	BTHV 12 DE	656.26	BTHV 12 A 12	180.50	BTHV 12 A 10	180.50	5

Connection set components	Ø 12 x 1.5 mm	Example: BTHV 5 A 12 for 5 component heating circuit distributor	Ø 10 x 1.3 mm	Example: BTHV 7 A 10 for 7 component heating circuit distributor
Ball valves R ¾"	2 units per distributor	2 units	2 units per distributor	2 units
Clamp connections	2 units per heating circuit	10 units	2 units per heating circuit	14 units
Angle clips	2 units per heating circuit	10 units	2 units per heating circuit	14 units



## Schlüter®-BEKOTEC-THERM-HVE

Schlüter®-BEKOTEC-THERM-HVE is a heating circuit distributor manifold expansion for the subsequent expansion of the Schlüter heating circuit distributor of stainless steel.

### The integrated and pre assembled set includes:

- Hot leg flow meter with transparent scale, adjustable 0.5 to 5.0 l / minute for regulating flow quantities
- Thermostat valve, adjustable manually for every heating circuit, matching the electronically controlled Schlüter actuators
- Heating circuit terminal with connector nozzle 3/4" (DN 20) AG with cone, matching the Schlüter clamp connections.

## Schlüter®-BEKOTEC-THERM-HVE

### heating circuit distributor expansion

Art.-No.	€/ Set	P (Set)
BTHVE 1 DE	99.42	5

### Note:

The connection to the Schlüter®-BEKOTEC-THERM heating pipes requires a set of clamp connections BTZ 2 KV ... as well as two angle clips BTZW 1418.



### Schlüter®-BEKOTEC-THERM-KH

**Schlüter®-BEKOTEC-THERM-KH** is a ball valve made of nickel plated brass, with 1" outside threading on one side (DN 25) for flat gasket connection to Schlüter heating circuit distributors and a connection pipe with 3/4" (DN 20) or 1" (DN 25) inside threading (shipping unit = set of two units for hot leg and cold leg).

### Schlüter®-BEKOTEC-THERM-KH

#### ball valve

DN	Art.-No.	€ / Set	P (Set)
20	BTZ2KH 20	26.53	10
25	BTZ2KH 25	38.62	10

set = 2 units



### Schlüter®-BEKOTEC-THERM-KV

**Schlüter®-BEKOTEC-THERM-KV** is a 3/4" (DN 20) clamp connection made of nickel plated brass for connection of Schlüter heating pipes, diameter 10, 12, 14 or 16 mm, to the Schlüter heating circuit distributor (shipping unit = set with two units for hot and cold leg).

### Schlüter®-BEKOTEC-THERM-KV

#### clamp connection

Ø mm	Art.-No.	€ / Set	P (Set)
10	BTZ2KV 10	8.64	10
12	BTZ2KV 12	8.64	10
14	BTZ2KV 14	8.05	10
16	BTZ2KV 16	8.05	10

set = 2 units



### Schlüter®-BEKOTEC-THERM-KU

**Schlüter®-BEKOTEC-THERM-KU** is a 3/4" (DN 20) connection coupling made of nickel plated brass for the connection of Schlüter heating pipes, diameter 12, 14 or 16 mm.

### Schlüter®-BEKOTEC-THERM-KU

#### connection coupling

Ø mm	Art.-No.	€ / U.	P (Unit)
12	BTZKU 12	14.08	10
14	BTZKU 14	12.52	10
16	BTZKU 16	12.52	10



### Schlüter®-BEKOTEC-THERM-KUS

**Schlüter®-BEKOTEC-THERM-KUS** is a 3/8" (DN 10) connection coupling made of nickel plated brass for the connection of Schlüter heating pipes, diameter 10 mm.

### Schlüter®-BEKOTEC-THERM-KUS

#### connection coupling

Ø mm	Art.-No.	€ / U.	P (Unit)
10	BTZKU 10 S	15.06	10



### Schlüter®-BEKOTEC-THERM-AN

**Schlüter®-BEKOTEC-THERM-AN** is a 1/2" x 3/4" connector fitting made of nickel plated brass. One side has a self sealing 1/2" (DN 15) external thread, while the other side features a 3/4" (DN 20) compression fitting for connecting the 14 mm or 16 mm Schlüter heating pipe.

Schlüter®-BEKOTEC-THERM-AN			
connector fitting			
Ø mm	Art.-No.	€ / Set	P (Set)
14	BTZ2AN 14	13.00	10
16	BTZ2AN 16	13.00	10

set = 2 units



### Schlüter®-BEKOTEC-THERM-AW

**Schlüter®-BEKOTEC-THERM-AW** is a 1/2" x 3/4" angled connection fitting made of nickel plated brass that can be rotated. One side has a self sealing 1/2" (DN 15) external thread, while the other side features a 3/4" (DN 20) compression fitting for connecting the 14 mm or 16 mm Schlüter heating pipe.

Schlüter®-BEKOTEC-THERM-AW			
angled connector fitting			
Ø mm	Art.-No.	€ / Set	P (Set)
14	BTZ2AW 14	25.10	10
16	BTZ2AW 16	25.10	10

set = 2 units



### Schlüter®-BEKOTEC-THERM-DA

**Schlüter®-BEKOTEC-THERM-DA** is a set of twin connectors made of nickel plated brass. It features a 3/4" (DN 20) cone joint nut on one side and two 3/4" (DN 20) cone connector threads on the other side for connecting the Schlüter heating pipes with diameters of 12 mm, 14 mm or 16 mm. The twin connector allows for setting up a second heating circuit at the control station BTBMS/RT. In this case, the heating circuits must have approximately the same lengths and performance ratings.

Schlüter®-BEKOTEC-THERM-DA		
twin connector		
Art.-No.	€ / Package	P (Package)
BTZ 2 DA	56.11	10

package = 2 units

**Note:**

The connection to the Schlüter®-BEKOTEC-THERM heating pipes requires 1 set of clamp connections BTZ 2 KV ... as well as two angle clips BTZW 1418.



### Schlüter®-BEKOTEC-THERM-S35

**Schlüter®-BEKOTEC-THERM-S35** is an offset connector made of nickel-plated brass, featuring a 3/4" (DN 20) cone joint nut on one side and a 3/4" (DN 20) cone connector nozzle on the other side for connecting Schlüter heating pipes with diameters of 10, 12, 14, or 16 mm. The offset connector can be used to cover offsets of up to 35 mm for connecting a Schlüter heating pipe to a Schlüter heating circuit distributor.

Schlüter®-BEKOTEC-THERM-S35		
offset connector		
Art.-No.	€ / U.	P (Unit)
BTZ S35	33.23	10

**Note:**

The connection to the BEKOTEC-THERM heating pipes requires additional clamp connections BTZ 2 KV... as well as angle clips.

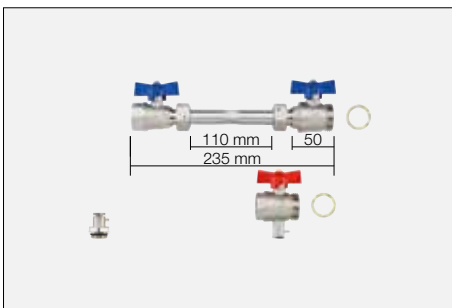
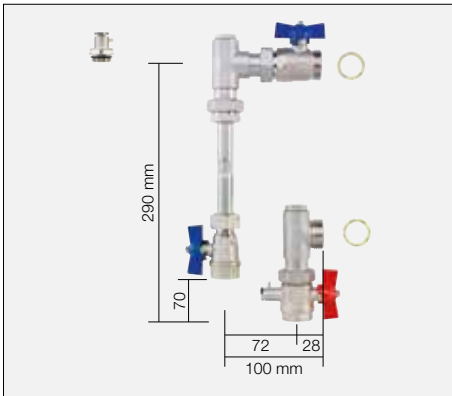
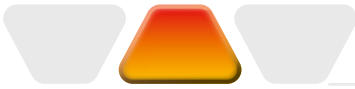

## Schlüter®-BEKOTEC-THERM-PW

Schlüter®-BEKOTEC-THERM-PW is a blank set for retrofitting the calorimeter, partly pre-installed.

### BTZPW 20 V vertical components:

- One spacer fitting, length 110 mm, with outside threading 3/4" (DN 20)
- Two 90° angles
- Two ball valves 3/4" (DN 20)
- One ball valve 3/4" (DN 20) with sensor connection for directly immersed sensors (5 mm, M10 x 1)
- Separate sensor connector 1/2" for directly immersed sensors (5 mm, M10 x 1)
- Two flat gaskets 1" (DN 25)

### BTZPW 20 H horizontal components:

- One spacer fitting, length 110 mm, with outside threading 3/4" (DN 20)
- Two ball valves 3/4" (DN 20)
- One ball valve 3/4" (DN 20) with sensor connection for directly immersed sensors (5 mm, M10 x 1)
- Separate sensor connector 1/2" for directly immersed sensors (5 mm, M10 x 1)
- Two flat gaskets 1" (DN 25)

## Schlüter®-BEKOTEC-THERM-PW

### pre plumb kit

Art.-No.	€ / Set	P (Set)
BTZPW 20 V	<b>133.79</b>	5
BTZPW 20 H	<b>95.79</b>	5

### Note:

The blank set for the measuring mechanism of the calorimeter is usually attached to the cold leg. Depending on the connection situation, it may become necessary to attach the distributor terminal for the cold leg above or below. Follow the manufacturer's instructions for the selected calorimeter.

The space requirements are important for the selection of the distributor cabinet (see table on page 27).

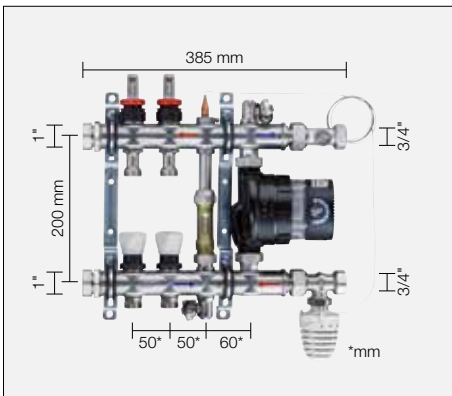

## Schlüter®-BEKOTEC-THERM-RVT/HV2

Schlüter®-BEKOTEC-THERM-RVT/HV2 is a fixed-value control station for setting the supply temperature. It contains two integrated heating circuits and can be expanded with a direct connection of the Schlüter®-BEKOTEC heating circuit distributor. They can be installed in the distributor cabinets VSE/VSV with an additional heating circuit distributor of 2 to max. 9 heating circuits. The fixed-value control supplies the Schlüter®-BEKOTEC-THERM ceramic thermal-comfort floor with the required low supply temperatures by adding heating water from warmer heating circuits (e.g. radiator circuits).

### The integrated and pre assembled set includes:

- High-efficiency pump with safety temperature limiter (STB)
- Thermostat valve (DN 20) 3/4" IG on the connection side, with adjustable thermostat head and immersion sensor (20-50°C)
- Stainless steel distributor bar for the supply line with end cap (DN 25)
- Stainless steel distributor bar for return line with end cap (DN 25)
- Adjustable return valve (DN 20), 3/4" IG on the connection side
- Adjustable bypass with flow indicator and immersion sensor (sensor recording)
- Supply line flow indicator for each heating circuit with a scale of 0.5 to 5.0 l/min

## Schlüter®-BEKOTEC-THERM-RVT/HV2

### control station for supply temperature DN 25

Art.-No.	€ / Set	P (Set)
BTRVT HV2 DE	<b>1054.30</b>	5

- Thermostat valve with manual adjustment cap for each heating circuit, to match retrofitting with Schlüter®-BEKOTEC actuators
- Filling and vent cock 1/2" (DN 15), rotating, nickel-plated brass
- 2 distributor brackets with sound insulation insert for installation in distributor cabinet VSE/VSV or for wall mounting
- system also includes two separate 3/4" blind caps for closing unused heating circuits

### Note:

The control technology and hydraulic conditions must be inspected by a qualified expert prior to installation. A supply pump (primary pump) must be installed. The installation and assembly instructions have to be followed.

We recommend the use of our "Control" base module. The integrated pump control switches off the pump of the fixed-value supply temperature control when all actuators at the heating circuit distributor are closed. This variation ensures the energy-efficient operation of the fixed-value control station.





### Schlüter®-BEKOTEC-THERM-ZV

**Schlüter®-BEKOTEC-THERM-ZV** is a heating zone valve that simultaneously operates all heating circuits connected to the **Schlüter®-BEKOTEC** heating circuit distributor by opening or closing. The heating zone valve can be controlled by a Schlüter actuator. The unit is controlled either by Schlüter control components or through an external control unit.

Connection/material: threaded connection/valve 1" (DN 25) of nickel plated brass.

Schlüter®-BEKOTEC-THERM-ZV		
heating zones valve		
Art.-No.	€ / U.	P (Unit)
BTZZV	51.33	5

**Note:**

Flow direction shown with an arrow on the valve to be observed during installation.

kvs = 4.2 m<sup>3</sup>/h



Art.-No. BTBMS

### Schlüter®-BEKOTEC-THERM-BMS Schlüter®-BEKOTEC-THERM-BMS/RT

The **Schlüter®-BEKOTEC-THERM-BMS** control station is a simple control concept to supply smaller areas equipped with one or two Schlüter®-BEKOTEC-THERM heating circuits.

The control station **Schlüter®-BEKOTEC-THERM-BMS/RT** is equipped with an additional interior thermostat that allows for switching the control station depending on room temperature.

The control station supplies the Schlüter®-BEKOTEC-THERM ceramic thermal comfort floor with the required low supply temperatures by mixing in heating water from warmer heating circuits, e.g. from the radiator circuit.

It is suitable for use in the **Schlüter®-BEKOTEC-THERM** distributor cabinet models BTVSE 4 and BTVSV 4. A second heating circuit can be implemented with an available set of twin connectors (order separately, Art.-No.: BTZ 2 DA). In this case, the heating circuits must have approximately the same lengths and performance ratings.

For further technical information please refer to the corresponding installation and operating instructions.

Schlüter®-BEKOTEC-THERM-BMS	
control station	
Art.-No.	€ / Set
BTBMS	817.20
BTBMS/RT	857.59

**Note:**

The clamp connections BTZ 2 KV... are not included with the control station and must be ordered separately to match the diameter of the heating pipes.

The control station is always installed at a level above the heating circuit.

Prior to installation, a qualified expert should inspect the control technology and hydraulic installations. The installation and assembly instructions of the manufacturer must be observed.



Art.-No. BTBMS/RT



### Schlüter®-BEKOTEC-THERM-RTB

**Schlüter®-BEKOTEC-THERM-RTB** is a return temperature limiter valve for concealed installation into the wall. It is installed at the end of a **Schlüter®-BEKOTEC-THERM** heating circuit and can be utilised to limit the water temperature in the preceding heating circuit. In addition, it serves to control the floor temperature in rooms with existing heaters. The temperature limiter can be adjusted to temperatures ranging from 20° to 40 °C.

#### The unit includes:

- Recessed wall installation box with adjustable installation depth W x H x D = 135 x 190 x 57 – approximately 75 mm
- Aperture, white, W x H = 145 x 200 mm
- Two attachment brackets
- RTB valve made of brass, including exhaust valve and flush valve with valve connections AG 3/4" (DN 20), which match the clamping ring threading BTZ 2 KV
- Thermostat head for return temperature, adjustable from 20° to 40°C
- Installation manual

### Schlüter®-BEKOTEC-THERM-RTB

#### return temperature limiter valve

Art.-No.	€ / U.	P (Unit)
BTRTB	179.03	5

#### Note:

The connection to the Schlüter®-BEKOTEC-BTHR heating pipes requires a set of clamp connections BTZ 2 KV.

The connector fitting BTZ 2 AN or the angled connector fitting BTZ 2 AW can be used at the transition to the existing heating system (see page 23).

Prior to installation, a qualified expert should inspect the control technology and hydraulic installations. The installation and assembly instructions of the manufacturer must be observed.

Maximum heating circuit lengths:

Heating pipe Ø 16 mm = 80 m

Heating pipe Ø 14 mm = 70 m

Heating pipe Ø 12 mm = 60 m

Heating pipe Ø 10 mm = 50 m



### Schlüter®-BEKOTEC-THERM-RRB

**Schlüter®-BEKOTEC-THERM-RRB** is a room temperature control valve with bypass function for installation in the wall. It can be used for the room temperature control of a heating circuit without additional auxiliary energy (power).

Prerequisite:

The heating water supply temperature may not exceed 50°C.

The unit is installed in the wall at the beginning of a Schlüter®-BEKOTEC-THERM floor heating circuit. The settings of the bypass valve allow for maintaining a consistent base temperature at the floor surface.

This prevents the floor from cooling off completely, and the base temperature for areas used with bare feet can be reliably set.

Thanks to a thermostat button, the room temperature is adjustable from 7° to 28°C.

#### The unit includes:

- Wall installation box with adjustable installation depth W x H x D = 135 x 190 x 57 mm
- Two attachment brackets
- Panel, white W x H = 145 x 210 mm, integrated room temperature control with adjustment range from 7° to 28°C
- RRB valve made of brass, including exhaust valve and flush valve with valve connections AG 3/4" (DN 20), which match the clamping ring threading BTZ 2 KV ...

### Schlüter®-BEKOTEC-THERM-RRB

#### room control valve with bypass

Art.-No.	€ / U.	P (Unit)
BTRRB	269.13	5

- Bypass valve for base volume flow
- Adjustment insert for overall volume flow
- Installation manual

#### Note:

The connection to the Schlüter®-BEKOTEC-BTHR heating pipes requires a set of clamp connections BTZ 2 KV.

The connector fitting BTZ 2 AN or the angled connector fitting BTZ 2 AW can be used at the transition to the existing heating system (see page 23).

Prior to installation, a qualified expert should inspect the control technology and hydraulic installations. The installation and assembly instructions of the manufacturer must be observed.

Maximum heating circuit lengths:

Heating pipe Ø 16 mm = 80 m

Heating pipe Ø 14 mm = 70 m

Heating pipe Ø 12 mm = 60 m

Heating pipe Ø 10 mm = 50 m



## Schlüter®-BEKOTEC-THERM-VSE

**Schlüter®-BEKOTEC-THERM-VSE** is a distributor cabinet for concealed mounting to house the Schlüter heating circuit distributor manifold and the matching control components. The concealed cabinet consists of galvanised steel with two stabilising double edges around the perimeter and perforations in the lateral walls for inserting the connector pipes.

### The unit includes:

- Two lateral height adjustable installation pedestals, adjustable from 0 to 90 mm
- Screed panel, height adjustable and removable
- Heating pipe rail
- Two adjustable attachment rails for Schlüter heating circuit distributor manifold and an additional installation rail for simple plug in installation of the Schlüter connection modules

### Note:

The powder coated frame and door come in separate packaging and can be retrofitted with four tuck flaps with wing screws, with variable attachment options for in wall openings of 110 to 150 mm. The door can be closed with a turning latch.

A lock with standard keys is available as a special accessory (Art.-No. BTZS).

Colour: BW = Brilliant white

Schlüter®-BEKOTEC-THERM-VSE							
distributor cabinet for concealed mounting							
Art.-No.	Outside dimensions (W x H x D = mm)	Maximum heating circuits without PW*	Maximum heating circuits with PW* vertical	Maximum heating circuits with PW* horizontal	Maximum heating circuits with incl. RVT**	€ / U.	P (Unit)
BTVSE 4 BW	490 x 705 x 110	4	2	0	2	<b>159.65</b>	5
BTVSE 5 BW	575 x 705 x 110	5	4	2	2	<b>175.98</b>	5
BTVSE 8 BW	725 x 705 x 110	8	7	5	5	<b>203.66</b>	5
BTVSE 11 BW	875 x 705 x 110	11	9	7	8	<b>228.98</b>	5
BTVSE 12 BW	1025 x 705 x 110	12	12	11	11	<b>257.31</b>	5
BTZS	Distributor cabinet lock with 2 standard keys					<b>18.46</b>	5

\* PW = blank set for calorimeter

\*\* RVT = fixed value control station BTRVT HV2 DE with two integrated heating circuit connections



## Schlüter®-BEKOTEC-THERM-VSV

**Schlüter®-BEKOTEC-THERM-VSV** is a distributor cabinet for surface mounting to house the Schlüter heating circuit distributor manifold and the matching control components. The distributor cabinet consists of galvanised steel with powder coating on the inside and outside.

### The unit includes:

- Two lateral height adjustable installation pedestals, adjustable from 0 to 90 mm
- Screed panel, removable
- Heating pipe rail
- Two adjustable attachment rails for Schlüter heating circuit distributor manifold and an additional installation rail for simple plug in installation of the Schlüter connection modules

### Note:

Cabinet depth: 125 mm. The door can be closed with a turning latch.

A lock with standard keys is available as a special accessory (Art.-No. BTZS).

Colour: BW = Brilliant white

Schlüter®-BEKOTEC-THERM-VSV							
distributor cabinet for wall mounting							
Art.-No.	Outside dimensions (W x H x D = mm)	Maximum heating circuits without PW*	Maximum heating circuits with PW* vertical	Maximum heating circuits with PW* horizontal	Maximum heating circuits with incl. RVT**	€ / U.	P (Unit)
BTVSV 4 BW	496 x 620 x 125	4	2	0	2	<b>215.69</b>	5
BTVSV 5 BW	582 x 620 x 125	5	4	2	2	<b>229.61</b>	5
BTVSV 8 BW	732 x 620 x 125	8	7	5	5	<b>248.77</b>	5
BTVSV 11 BW	882 x 620 x 125	11	9	7	8	<b>266.21</b>	5
BTVSV 12 BW	1032 x 620 x 125	12	12	10	11	<b>303.46</b>	5
BTZS	Distributor cabinet lock with 2 standard keys					<b>18.46</b>	5

\* PW = blank set for calorimeter

\*\* RVT = fixed value control station BTRVT HV2 DE with two integrated heating circuit connections



### Schlüter®-BEKOTEC-THERM-ER/WL

**Schlüter®-BEKOTEC-THERM-ER/WL** is a “cooling/heating” room sensor with a flat design.

The wireless device transmits the current room temperature and the set-point value to the connection module for WL room sensors.

The set-point temperature is adjustable from 8° to 30°C and can be restricted below the dial with set-point limiters. An additional timer unit on the “Control” base module can effect a time-controlled temperature reduction of 4°C.

An integrated photovoltaic cell allows for battery-free operation. The supplied 3 V button cells can be used for rooms with insufficient light yield.

### Schlüter®-BEKOTEC-THERM-ER/WL

**room sensor, wireless**

Art.-No.	€ / U.	P (Unit)
BT ER WL/BW	<b>172.59</b>	10

Colour: BW = Brilliant white

Dimensions W/H/D: 78 x 82.5 x 12.5 mm



### Schlüter®-BEKOTEC-THERM-ER

**Schlüter®-BEKOTEC-THERM-ER** is a “cooling/heating” room sensor with a flat design for wired thermostats.

The device transmits the current room temperature and the set-point value to the connection module for room sensors.

The set-point temperature is adjustable from 8° to 30°C and can be restricted below the dial with set-point limiters. A timer unit on the “Control” base module can effect a time-controlled temperature reduction of 4°C.

The room sensor is operated with 5 V DC safety extra-low voltage (SELV) via the “Control” base module in conjunction with the connection module for room sensors.

The operating state “heating/cooling” is displayed by the “red/blue” colour change of a light-emitting diode (LED).

### Schlüter®-BEKOTEC-THERM-ER

**room sensor, wired**

Input voltage	Art.-No.	€ / U.	P (Unit)
5 V, DC	BT ER/BW	<b>45.26</b>	10

Colour: BW = Brilliant white

Dimensions W/H/D: 78 x 78 x 12.5 mm

#### Note:

Only cables with maximum wire cross-sections of 0.8 mm<sup>2</sup> may be connected between the room sensors Schlüter®-BEKOTEC-THERM-ER and the connection modules Schlüter®-BEKOTEC-THERM-EAR.

#### Cable recommendation:

BTZK 4A 100M,  
J-Y (St) Y 2 x 2 x 0.6 mm  
(red, black, white, yellow)



### Schlüter®-BEKOTEC-THERM-EBC

**Schlüter®-BEKOTEC-THERM-EBC** is the necessary “Control” base module for the operation of wired as well as wireless thermostats.

Both wireless and/or wired connection modules for the room sensors are connected to the “Control” base module, which makes it easy to realise mixed installations and upgrades.

The base module supplies the wired room sensors with 5 V DC safety extra-low voltage (SELV) via the corresponding connection modules and controls the connected actuators with 230 V AC. The operating state as well as the voltage supply of the input/output is clearly indicated by LEDs.

### Schlüter®-BEKOTEC-THERM-EBC

**“Control” base module**

Input voltage	Art.-No.	€ / U.	P (Unit)
230 V, AC	BT EBC	<b>142.60</b>	5

Dimensions W/H/D: 122 x 92 x 45 mm

#### Other features of the “Control” base module

- Slot for optional timer unit
- Pump circuit (relay) “Heating”
- Pump circuit (relay) “Cooling”
- Cascade output for connecting the heating/cooling output to additional base modules
- Input for “heating/cooling” switch



### Schlüter®-BEKOTEC-THERM-EET

**Schlüter®-BEKOTEC-THERM-EET** is a timer unit for time-controlled temperature reduction. It can be removed and re-inserted into the "Control" base module to program a time-controlled temperature reduction. A temperature reduction of 4°C is then effected in the timed periods.

Due to the quick responsiveness of the BEKOTEC-THERM ceramic thermal comfort floor, the timer unit meets the requirements for quickly controllable systems.

Schlüter®-BEKOTEC-THERM-EET		
Timer unit		
Art.-No.	€ / U.	P (Unit)
BT EET	173.64	5

Dimensions W/H/D: 37 x 92 x 28 mm

#### Features

- Time recording/programming: date, time, weekdays
- Time recording/programming of temperature reduction
- Setting the deferred pump shut-down
- Setting the valve and pump protection function

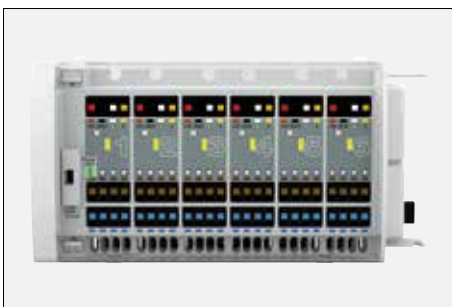

BT EAR 6



BT EAR 2

### Schlüter®-BEKOTEC-THERM-EAR

**Schlüter®-BEKOTEC-THERM-EAR** are modules for connecting 2 or 6 BT ER wired room sensors. The connection modules BT EAR2 for 2 or BT EAR6 for 6 room sensors can be combined by simply plugging them together in order to adjust the number of rooms/heating circuits to be regulated or to adjust and expand the actuators to be assigned. Each channel of the connection module can be assigned to 4 actuators. A combination with the wireless connection modules Schlüter®-BEKOTEC-THERM-EAR/WL (wireless) is possible. The "Control" base model Schlüter®-BEKOTEC-THERM-EBC provides the 5 V DC supply voltage (SELV) for the room sensors and 230 V voltage for the actuators.

The operating state as well as the voltage supply of the input/output is clearly indicated by LEDs.

Schlüter®-BEKOTEC-THERM-EAR			
connection module for wired room sensors			
Input voltage	Art.-No.	€ / U.	P (Unit)
230 V, AC	BT EAR 2	104.70	5
230 V, AC	BT EAR 6	158.91	5

Dimensions W/H/D: 73 x 92 x 45 mm (BT EAR 2)  
Dimensions W/H/D: 162 x 92 x 45 mm (BT EAR 6)

#### Note:

Only cables with maximum wire cross-sections of 0.8 mm<sup>2</sup> may be connected between the room sensors Schlüter®-BEKOTEC-THERM-ER and the connection modules Schlüter®-BEKOTEC-THERM-EAR.

#### Cable recommendation:

BTZK 4A 100M,  
J-Y (St) Y 2 x 2 x 0.6 mm  
(red, black, white, yellow)



BT EAR 6 WL



BT EAR 2 WL

### Schlüter®-BEKOTEC-THERM-EAR/WL

**Schlüter®-BEKOTEC-THERM-EAR/WL** are connection modules for connecting 2 or 6 BT ER WL wireless room sensors.

The connection modules BT EAR2 WL for 2 or BT EAR6 WL for 6 room sensors can be combined by simply plugging them together in order to adjust the number of rooms/heating circuits to be regulated or to adjust and expand the actuators to be assigned. Each channel of the connection module can be assigned to 4 actuators. A combination with the wired connection modules Schlüter®-BEKOTEC-THERM-EAR is possible.

The "Control" base model Schlüter®-BEKOTEC-THERM-EBC provides the 230 V voltage for the actuators.

The operating state as well as the voltage supply of the input/output is clearly indicated by LEDs.

### Schlüter®-BEKOTEC-THERM-EAR/WL

#### connection module for wireless room sensors

Input voltage	Art.-No.	€ / U.	P (Unit)
230 V, AC	BT EAR 2 WL	<b>299.92</b>	5
230 V, AC	BT EAR 6 WL	<b>420.94</b>	5

Dimensions W/H/D: 73 x 92 x 45 mm (BT EAR 2 WL)

Dimensions W/H/D: 162 x 92 x 45 mm (BT EAR 6 WL)



### Schlüter®-BEKOTEC-THERM-ESA

**Schlüter®-BEKOTEC-THERM-ESA** is an actuator for either 230 Volt or 24 Volt to control the flow of the cold leg valves. It is mounted by plugging into the valves of the cold leg of the Schlüter heating circuit distributor. Actuators are equipped with a volume display, including a control function of the valve adapters and a protection mechanism against moisture. The valve is delivered in open condition (first open function).

Zero current circuit

Connector cable 1 m, plug in type

### Schlüter®-BEKOTEC-THERM-ESA

#### actuator

Input voltage	Art.-No.	€ / U.	P (Unit)
24 V	BTESA 24	<b>48.72</b>	10
230 V	BTESA 230	<b>48.72</b>	10

Dimensions W/H/D: 44 x 51 x 48 mm

#### Note:

The 230 Volt actuator must be used for BEKOTEC connection modules.



### Schlüter®-BEKOTEC-THERM-ZK

**Schlüter® BEKOTEC-THERM-ZK 4A** is a cable to connect the room sensors Schlüter®-BEKOTEC-THERM-ER with the connection modules BT EAR2 or BT EAR6.

### Schlüter®-BEKOTEC-THERM-ZK

#### connection cable

L (m)	Art.-No.	€ / U.	P (Unit)
100	BTZK 4A 100M	<b>52.09</b>	10

#### Note:

Only cables with maximum wire cross-sections of 0.8 mm<sup>2</sup> may be connected between the room sensors Schlüter®-BEKOTEC-THERM-ER and the connection modules Schlüter®-BEKOTEC-THERM-EAR.



## Schlüter®-DITRA-HEAT-E Electrical wall heating – meets additional heat demand in bathrooms

Due to their size, bathrooms are often difficult to heat with a floor heating system. In such cases, the electrical wall heating system Schlüter®-DITRA-HEAT-E is an ideal supplement for a ceramic thermal comfort floor to cover the existing heat demand. The zones to be heated can be individually adapted to the requirements of developers and users, for example by integrating a heated wall in a shower area.

- ✓ Durable and maintenance-free.
- ✓ Easy to retrofit.
- ✓ Fast heat-up response.
- ✓ Simple to install.
- ✓ Low assembly height.
- ✓ Control via touchscreen or app.
- ✓ Convenient complete sets.

For more information, visit our website at:  
<http://www.schluter-systems.com>

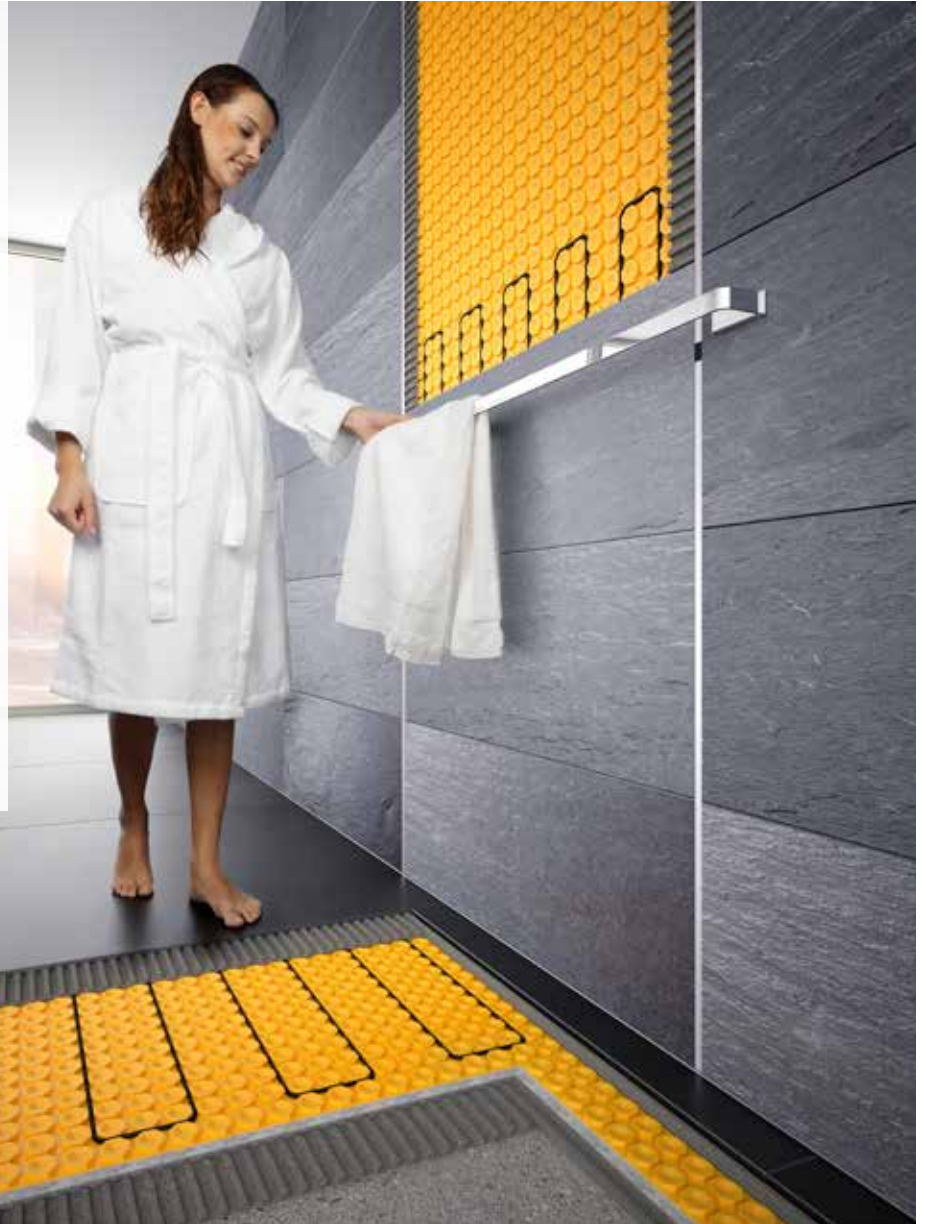



## Schlüter®-BEKOTEC-THERM – Calculation aid

Calculation components	Single-family home						
	... EN/P	... EN/PF	... EN 23 F	... EN 18 FTS		... EN 12 FK	
System BT	VA 150	VA 150	VA 150	VA 100	VA 150	VA 100	VA 150
Grid spacing VA/mm	VA 150	VA 150	VA 150	VA 100	VA 150	VA 100	VA 150
Heating pipe requirements in m/m <sup>2</sup>	6.66	6.66	6.66	10.00	6.66	10.00	6.66
List price	€/m <sup>2</sup>	€/m <sup>2</sup>	€/m <sup>2</sup>	€/m <sup>2</sup>	€/m <sup>2</sup>	€/m <sup>2</sup>	€/m <sup>2</sup>
Cost for:							
– Studded screed panels							
– edging strip							
– DILEX-DFP Expansion joint profiles							
– Heating pipes	ca. 48.50	ca. 52.70	ca. 51.50	ca. 72.60	ca. 59.20	ca. 66.00	ca. 54.00
– Heating circuit distributors and accessories							
– Distributor cabinets							
– Room sensor/control technology (without time control)							

Calculation components	500 m <sup>2</sup> exhibition spaces / open spaces					
	... EN/P		... EN/PF		... EN 23 F	
System BT	VA 225	VA 300	VA 225	VA 300	VA 225	VA 300
Grid spacing VA/mm	VA 225	VA 300	VA 225	VA 300	VA 225	VA 300
Heating pipe requirements in m/m <sup>2</sup>	4.44	3.33	4.44	3.33	4.44	3.33
List price	€/m <sup>2</sup>	€/m <sup>2</sup>	€/m <sup>2</sup>	€/m <sup>2</sup>	€/m <sup>2</sup>	€/m <sup>2</sup>
Cost for:						
– Studded screed panels						
– edging strip						
– DILEX-DFP Expansion joint profiles						
– Heating pipes	ca. 29.40	ca. 26.70	ca. 33.10	ca. 30.50	ca. 30.50	ca. 27.80
– Heating circuit distributors and accessories						
– Distributor cabinets						
– Room sensor/control technology (without time control)						

Prices guaranteed until December 31, 2019  
Prices exclude VAT

### Additional structural components:

impact sound insulation

Heat insulation

Screed

Schlüter®-DITRA 25 or Schlüter®-DITRA-DRAIN 4

Thin-bed tile adhesive

Coverings

Schlüter®-DILEX intermediate movement joints

Schlüter®-DILEX perimeter movement joints

The cost of the **Schlüter®-BEKOTEC-THERM** floor heating system depends on several project-specific factors. Calculation factors include the number and size of rooms, the number of heating circuits, the heating pipe spacing as well as the desired control technology. Based on our experience, we compiled the gross material costs for all required BEKOTEC-THERM components, including the necessary control technology for a typical single-family home, per square metre. As an alternative, we also calculated an average price per square metre for a large space of 500 m<sup>2</sup>, such as an exhibition hall. Prices do not include the cost of labour and are shown in the table. These values only represent calculated guidelines, which may differ for specific projects. Further installation components, such as insulation, Schlüter®-DITRA 25, Schlüter®-DITRA-HEAT or Schlüter®-DITRA-DRAIN 4 and the covering need to be taken into account as well.





# Schlüter®-BEKOTEC-THERM

## Additional system components

The Schlüter products described below are mandatory system components for damage free ceramic tile or natural stone coverings in conjunction with **Schlüter®-BEKOTEC-THERM** (see separate price list).

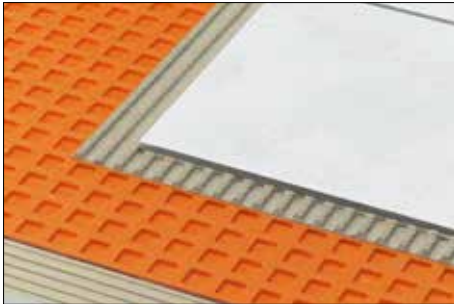

### Schlüter®-DITRA

Uncoupling mat

Schlüter®-DITRA uncouples the ceramic or natural stone covering from the screed, preventing the transfer of stresses or cracks from the substrate to the covering and ensuring even heat distribution. Schlüter®-DITRA can be used for bonded waterproofing in moist environments (for further information, please see product data sheets 6.1).

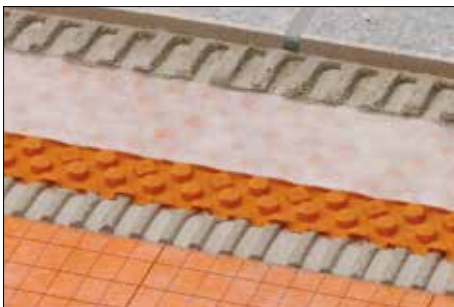

### Schlüter®-DITRA-DRAIN

Uncoupling mat

Schlüter®-DITRA-DRAIN 4 uncouples ceramic tile or natural stone coverings from the screed, prevents the transfer of stresses or cracks from the substrate to the surface, and ensures even heat distribution. Thanks to the full subaeration of the covering, Schlüter®-DITRA-DRAIN 4 enables the quick and thorough curing of the thin bed adhesive even in large dimensions (for more information, see product data sheet 6.2).



### Schlüter®-DILEX

Intermediate movement joint profiles

Schlüter®-DILEX-BWB/-BWS/-KS/-EDP/-AKWS are movement joint profiles, which are installed for creating the necessary joint pattern of the covering over the Schlüter uncoupling mat. They effectively absorb expansions, e.g. those caused by temperature changes (for further information, please see product data sheets 4.6, 4.7, 4.8, 4.16, 4.18).



### Schlüter®-DILEX

Perimeter movement joint profiles

Schlüter®-DILEX-EK/-RF are flexible corner profiles for the transition areas to skirting or wall tiles. Schlüter®-DILEX-BWA/-AS are profiles for flexible connections to structural building elements (for further information, please see product data sheets 4.9, 4.10 and 4.14).



## Schlüter-Systems online

The website [www.bekotec-therm.com](http://www.bekotec-therm.com) offers four easy steps to calculate a price estimate for your individual construction project. Quickly, without registration or entering personal data.

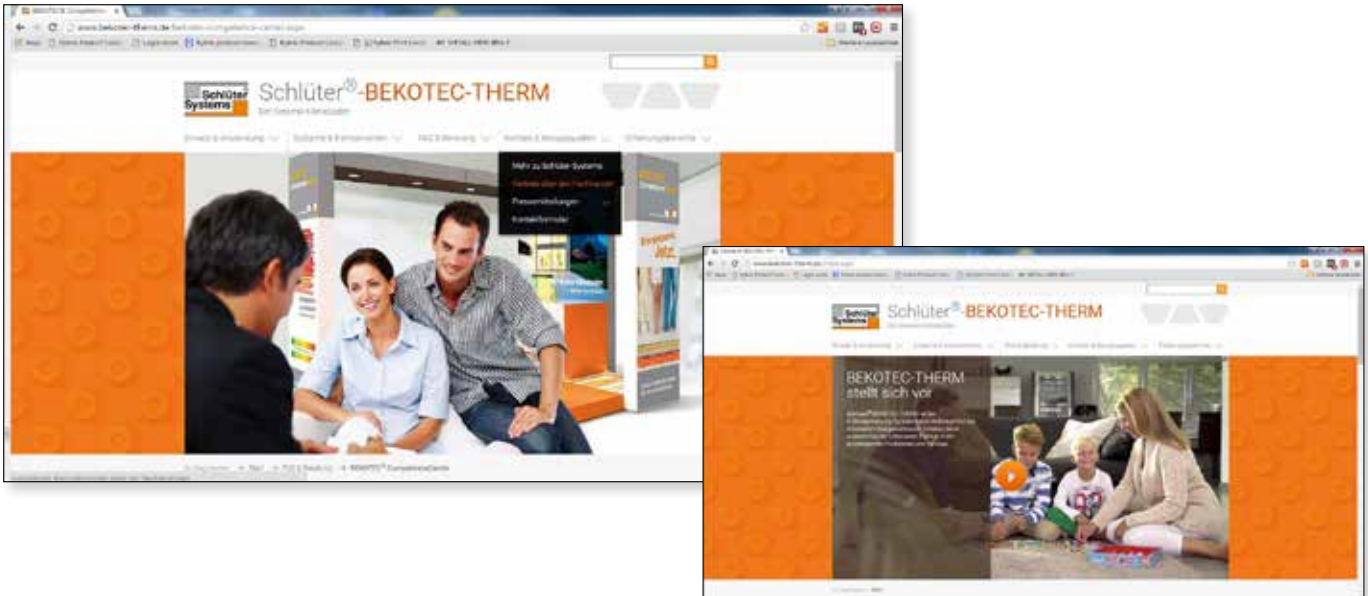

A complete overview of our system products can be found at [www.schluter-systems.com](http://www.schluter-systems.com). Simple. Clearly structured. Fast. Download data sheets, ask questions, or simply find the information you need.

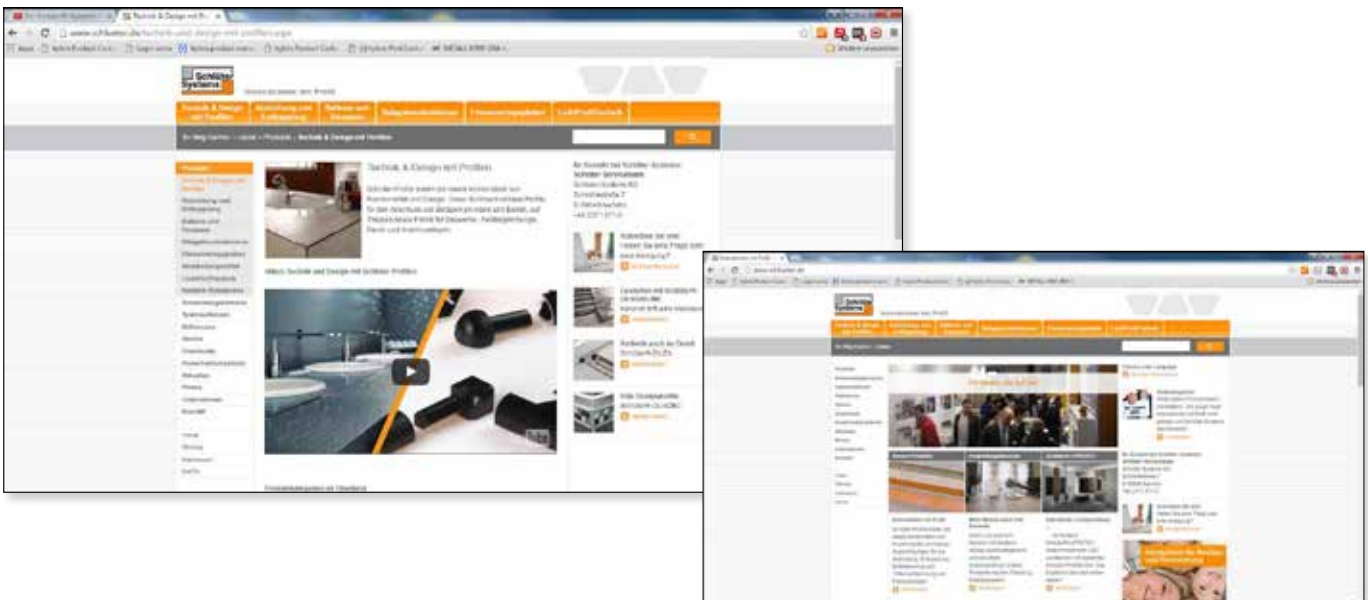

## **Delivery and Payment Conditions**

### **1. General**

By placing his order, the purchaser agrees to the following delivery and payment conditions. These conditions shall remain in effect throughout the business relationship unless expressly altered in writing.

We reject all delivery and payment conditions of purchasers that differ from our own. Individual differing purchase conditions shall only be binding if we confirm them in writing.

### **2. Offers and prices**

Unless expressly agreed to the contrary, all offers are understood to be non-binding and subject to change without notice. For all deliveries, the sales price shall be the current price in effect on the day of delivery. The most recently published price list shall supersede all others. Unless otherwise specified, prices are quoted without VAT.

### **3. Delivery, acceptance, place of performance**

For all orders, shipment shall be made at the expense and risk of the purchaser from either the production plant or our warehouse, even in the event of pre-paid freight delivery. We shall not be held liable for damage incurred during shipping or at the final destination. Purchasers shall claim any damage or losses from the shipping company prior to accepting a shipment. Delivery possibility is reserved for all orders. Delayed deliveries shall entitle the purchaser to rescind an order, but shall not represent an entitlement to damages. We accept no liability for timely delivery.

### **4. Warranty**

Complaints concerning defects must be lodged immediately after receipt of the goods and before the installation of any products. Cancellation or reduction may be demanded, but the customer shall be entitled to no other claims of any kind as a result of defective delivery. The place of performance shall be, even for pre-paid delivery, the loading dock in Iserlohn.

For sales according to sample, it shall be warranted only that merchandise shall conform to the sample characteristics. We expressly refer the purchaser to the information in our most current brochures and technical data sheets for product installation. No warranty is made of suitability for any specific application. Advice and instructions for use are given in good faith on the basis of experience and testing, and in accordance with the best of our knowledge, but no liability on our part may be derived therefrom, unless the defectiveness of the delivered product entitles the purchaser to claim warranty or liability payments required by law. Depending on the individual installation situation, users of the product shall be responsible for conducting their own professionally qualified assessment of the product prior to any use of the product to verify it is free of defects and usable. In cases of installing products that do not comply with the state of the art, e.g., due to their novelty, the customer (installer) shall be responsible for making the appropriate arrangements with the property developer.

### **5. Payment**

Invoice amount must be paid in Euros by the Payment Due Date. Rebates and discounts are granted by special arrangement only. Cash discounts on new invoices are not applicable until all due invoices are paid. In the event of payment in arrears, we shall be entitled to claim interest on the payable amount at an amount by 5% higher than the basic interest rate (§247(1), German Civil Code) p.a., starting from the first day of arrears and without additional notification. Acceptance, bills of exchange or cheques taken in payment shall be considered as such only after they have been honoured. Nonconformity to payment terms, or other credit-limiting factors that become apparent after entering the contract agreement, will cause all outstanding invoices to become due immediately and allow us to cancel the contract.

Deliveries to customers who are not known to us, or in the case of small orders, or for any other reason which appears necessary to us, may be sent by us cash on delivery, or (in the event of pick up) cash payment may be demanded upon pick up.

### **6. Retention of title**

The merchandise shall remain our property until all of our claims arising from the business relationship with the purchaser shall be fully paid. The purchaser shall be obliged to notify us of any actions by third parties affecting the delivered merchandise which is under retention of title.

If the delivered merchandise or objects produced from their further processing are resold by the purchaser or installed in a real estate property belonging to a third party, in such a way that they become essential components of that third party's property, then all claims and ancillary rights arising from the seller from such sale or installation vis-à-vis this buyer or third parties shall be assigned to us.

A special declaration of assignment shall not be required. Rights arising from the retention of title shall remain in effect until the complete release from all contingent liabilities which the seller/deliverer has undertaken in the interest of the purchaser/buyer.

### **7. Variations**

Changes with respect to the preceding conditions shall be effective only if agreed to in writing. Verbal or agreements shall be valid only if they are confirmed in writing. Conflicting conditions of the purchaser cannot be recognized. Should individual provisions of these delivery and payment conditions be found contrary to binding law, the legal validity of the remaining provisions shall not be affected.

### **8. Jurisdiction and final note**

The place of jurisdiction shall be Iserlohn or Hagen, including in matters involving bills of exchange or checks, if the purchaser is a registered merchant or if the remaining conditions of § 38, Code of Civil Procedure, apply. All disputes arising from this agreement shall exclusively be subject to the law of the Federal Republic of Germany, exactly as it is applicable to domestic business transactions between domestic parties. The invalidity of individual provisions of these delivery and payment conditions shall not affect the remaining provisions.

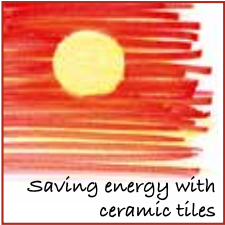

Saving energy with ceramic tiles

... made by Schlüter-Systems  
www.bekotec-therm.com



www.bekotec-therm.com



## Schlüter®-DITRA-HEAT-E

The ideal complement for even greater comfort of living!

**Electrical floor heating with Schlüter®-DITRA technology.**

**System-compatible with Schlüter®-BEKOTEC-THERM.**

For more information visit [www.schlueter-systems.com](http://www.schlueter-systems.com).



Presented by (your construction materials specialist):



All previous price lists lose their validity on the publication of this price list.  
Errors, changes, and printing mistakes as well as changes necessary in the interest of product innovation or shipping reserved. For reasons of printing, colours shown in this price list may differ from actual product colours.



PROFILE OF INNOVATION

Schlüter-Systems KG · Schmölestraße 7 · D-58640 Iserlohn  
Tel.: +49 2371 971-0 · Fax: +49 2371 971-111 · info@schlueter.de · www.bekotec-therm.com